

Driver: \_\_\_\_\_  
 Date: \_\_\_\_\_

Track: \_\_\_\_\_  
 Event: \_\_\_\_\_

## FRONT

Ride Height:
Camber:
Toe:
Anti-Roll Bar
Size:
Gap:
Ackerman
Drive Shaft:
Chassie Brace:
Hex:

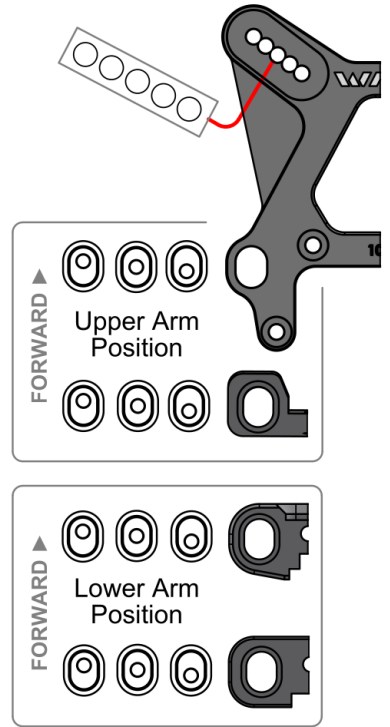
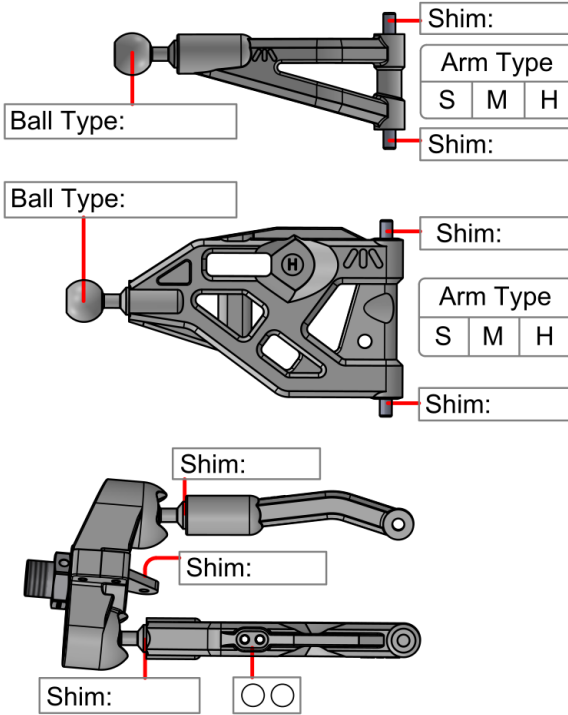
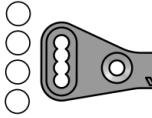
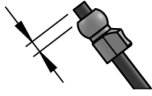

## REAR

Ride Height:
Camber:
Toe:
Anti-Roll Bar
Size:
Gap:
Drive Shaft:
Chassie Brace:
Hex:

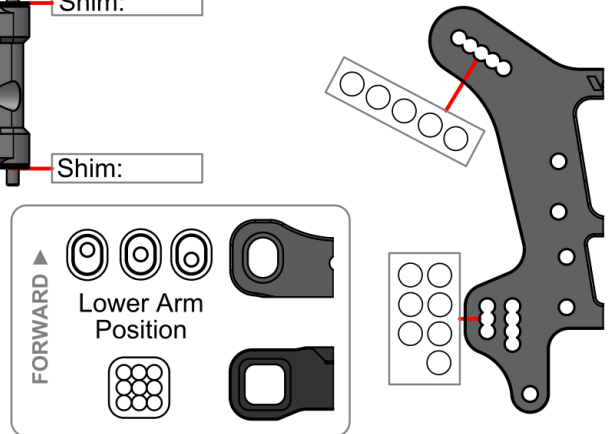
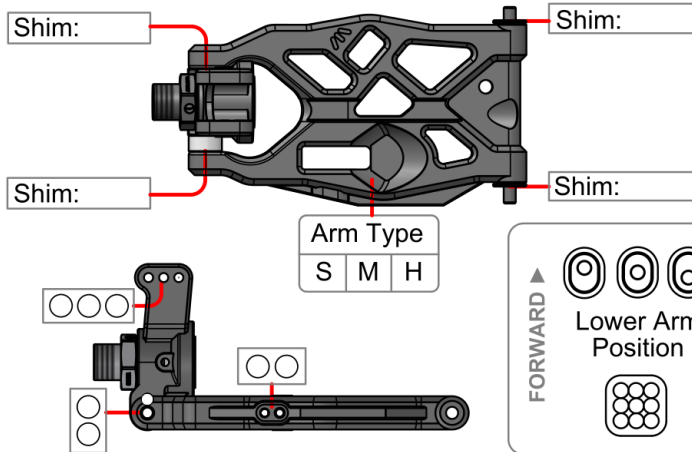
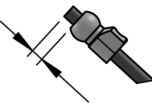

## SHOCKS

	Front	Rear
Piston:		
Membrane:		
Oil:		
Spring:		
Rebound:		
Free Length:		

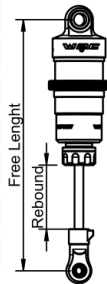

## DIFFERENTIAL

	Front	Center	Rear
Case Mat.:			
Oil:			
Crown Gear:			
Clutch Belt:		Spur Gear	
Shoe:		Spring	

## GEARING

## TYRES

	Front	Rear
Brand:		
Pattern:		
Insert:		
Wheels:		
Compound:		

## ENGINE

Type:
Muffler:
Manifold:
Plug:

## BODY & WING

Body:
Wing:
Wing Height:
Gap to tower:

## NOTES / OPTIONALS

-----

-----

-----

-----

-----

## TRACK

Size :
Traction:
Surface:

Total Vehicle Weight: \_\_\_\_\_