

GT4E.2

NEW GENERATION RC CAR

ONROAD ELECTRIC GT
1/8 SCALE 4WD



INSTRUCTION MANUAL

WRC
PROFESSIONAL RC CAR

WWW.WIRCRACING.COM



INTRODUCTION

GT4E is a new generation high quality 1/8 scale GT electric car.

GT4E is supplied in a box, you can download the Instruction manual from www.wircracing.com

Its use is intended for more than 16 years old persons with experience on rc model car field.

Children and all the persons without this requirement MUST have direct supervision of a knowledgeable adult responsible.

SAFETY PRECAUTIONS

Instruction Manual MUST be read and fully understood before to start building and operating functions.

Always keep Instruction Manual in safety place, ready to be consulted for any reference you need.

Use only original WIRC spare parts.

GENERAL INFORMATION

Assemble the kit only away from the reach of children.

Follow the building and operating instructions using the utmost care.

Don't put any part of your body inside rotating and moving elements as this may cause damage or serious injury.

Check and clean the model before putting it away.

Don't use your model car in public places or in roads and areas where it could generate conflict with person or vehicular traffic.

The model car is controlled by radio: you MUST put great care to avoid loss of radio control always keeping a safety margin all around your model in order to prevent any collision.

Operating frequency: check and be sure it is clear and not shared with anybody at same time; it could cause loss of control of the RC model.

Always turn on your transmitter before you turn on the receiver in the car and always turn off the receiver before you turn off your transmitter.

Keep the wheels of the model off the ground when checking the operation of the radio equipment.

Disconnect the battery pack before storing your model.

WARRANTY

WIRC guarantees this model kit to be free from defects in both material and workmanship within 30 days of purchase.

The total monetary value under warranty will in no case exceed the cost of the original kit purchased.

This warranty doesn't cover any components damaged by use or modification or as result of wear.

Part or parts missing from this kit must be reported within 30 days of purchase.

No part or parts will be sent under warranty without proof of purchase.

If you find a defective or missing part, contact the local distributor.

Customer service and support will be provided through local hobby store.

No warranties are expressed or implied that cover damage caused by what is considered normal use or cover or imply how long any model cars' components or electric components will last before requiring replacement.

Due to the high performance level of this model car you will need to periodically maintain and replace consumable components; any and all warranty coverage will not cover replacement of any part or component damaged by neglect, abuse or improper or unreasonable use.

This includes but is not limited to damage from crashing, excessive moisture, improper use or no maintenance or user modifications which compromise the integrity of components.

Warranty will not cover components that are considered consumable on RC model car.

WIRC doesn't pay nor refund on any component sent from WIRC or its distributor for warranty.

WIRC reserves the right to make final determination of the warranty status of any component or part

Use only original WIRC spare parts.

CUSTOMER SUPPORT

Please don't hesitate to contact WIRC support at info@wircracing.com for any problem or question.

Also kindly visit our website www.wircracing.com to find last updates, set-up, option parts and other informations.

World racing car s.r.l.

Via A. Volta 2 Bis
36040 Brendola (VI)

ITALY

Phone: 0039 0444 1792263

E-mail: sales@wircracing.com

Website: www.wircracing.com



GT4E

TECHNICAL INFORMATION

- WHEELS LOCK: Lightweight 17 mm 7075 T6 Nut
- CHASSIS: 4.0 mm Swiss 7075 T6 aluminium
- RADIO PLATE: Composite Material
- DRIVETRAIN TYPE: Spring steel CVD Driveshfts
- FRONT DIFFERENTIAL: Differential Gear
- REAR DIFFERENTIAL: Differential Gear
- SUSPENSION: Pivot ball suspension
- RIDE HEIGHT: Adjustable Front & Rear
- CAMBER: Adjustable Front & Rear
- CASTER: Adjustable Front
- TOE: Adjustable Front & Rear
- ROLL CENTER: Adjustable Front & Rear
- ACKERMANN: Adjustable Front
- ANTI-ROLL BARS: Adjustable Front & Rear

TECHNICAL DATA

- WIDTH310 mm
- WHEEL BASEadjustable 315-320 mm
- WEIGHT READY TO RUN.....3500g

ADDITIONAL ITEMS NEEDED FOR COMPLETION (REQUIRED BUT NOT INCLUDED IN THE KIT)



ENGINE AND MUFFLER



TRANSMITTER



RECEIVER



LOW PROFILE STEERING SERVO



BATTERIES FOR TRANSMITTER AND RECEIVER



WHEEL - TYRES - INSERTS



2 X 7.4 V
LIPO BATTERIES

TOOLS REQUIRED

THESE TOOLS ARE NOT INCLUDED IN THE KIT BUT ARE REQUIRED FOR PROPER ASSEMBLY



ALLENS:
1.5 mm
2 mm
2.5 mm
3 mm



SOCKET
5mm



SIDE CUTTERS



COMBINATION PLIERS



TOOL FOR
TURNBUCKLES/NUTS



WHEEL NUT TOOL
17mm



GREASE



OILS:
5000 CST
BEARING OIL

NOTICE:

THE FOLLOWING ITEMS ARE NEEDED FOR COMPLETION OF THE GT4E; THEY ARE NOT INCLUDED IN THIS KIT (UNLESS NOTED) AND SHOULD BE OBTAINED FROM YOUR LOCAL HOBBY SHOP. BE SURE TO READ THE INSTRUCTION COMPLETELY PRIOR TO ASSEMBLY

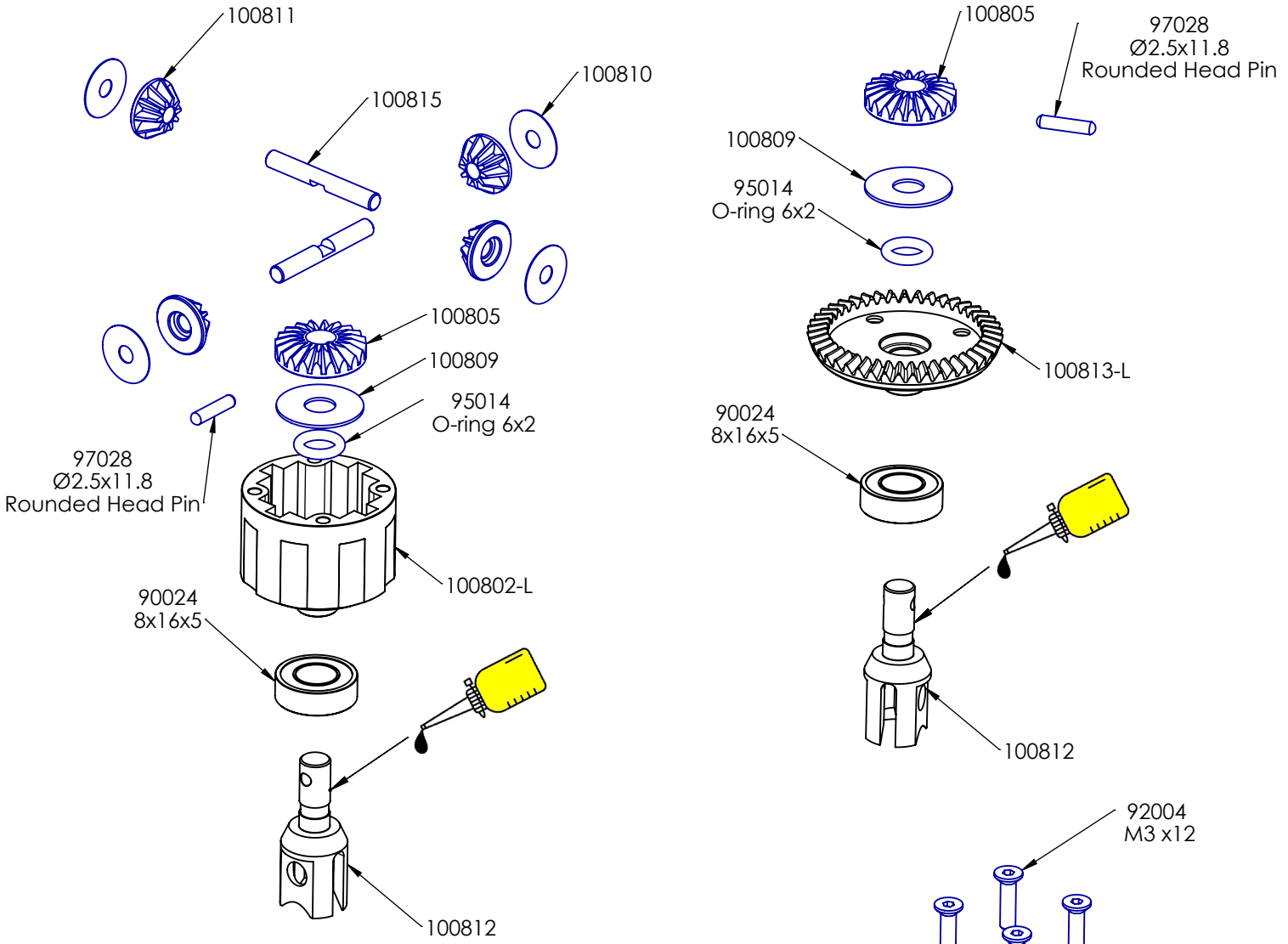

 **DIFFERENTIAL OIL :**
Front : 1000000 cst
Weight : 3 g

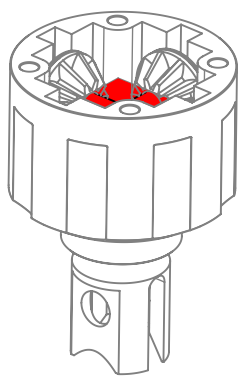

**Fill the differential up to the top of the pin.
DO NOT fill the diff. to the top of the housing.**

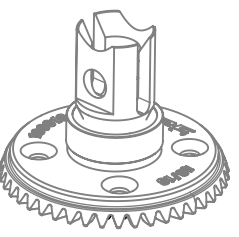

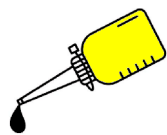
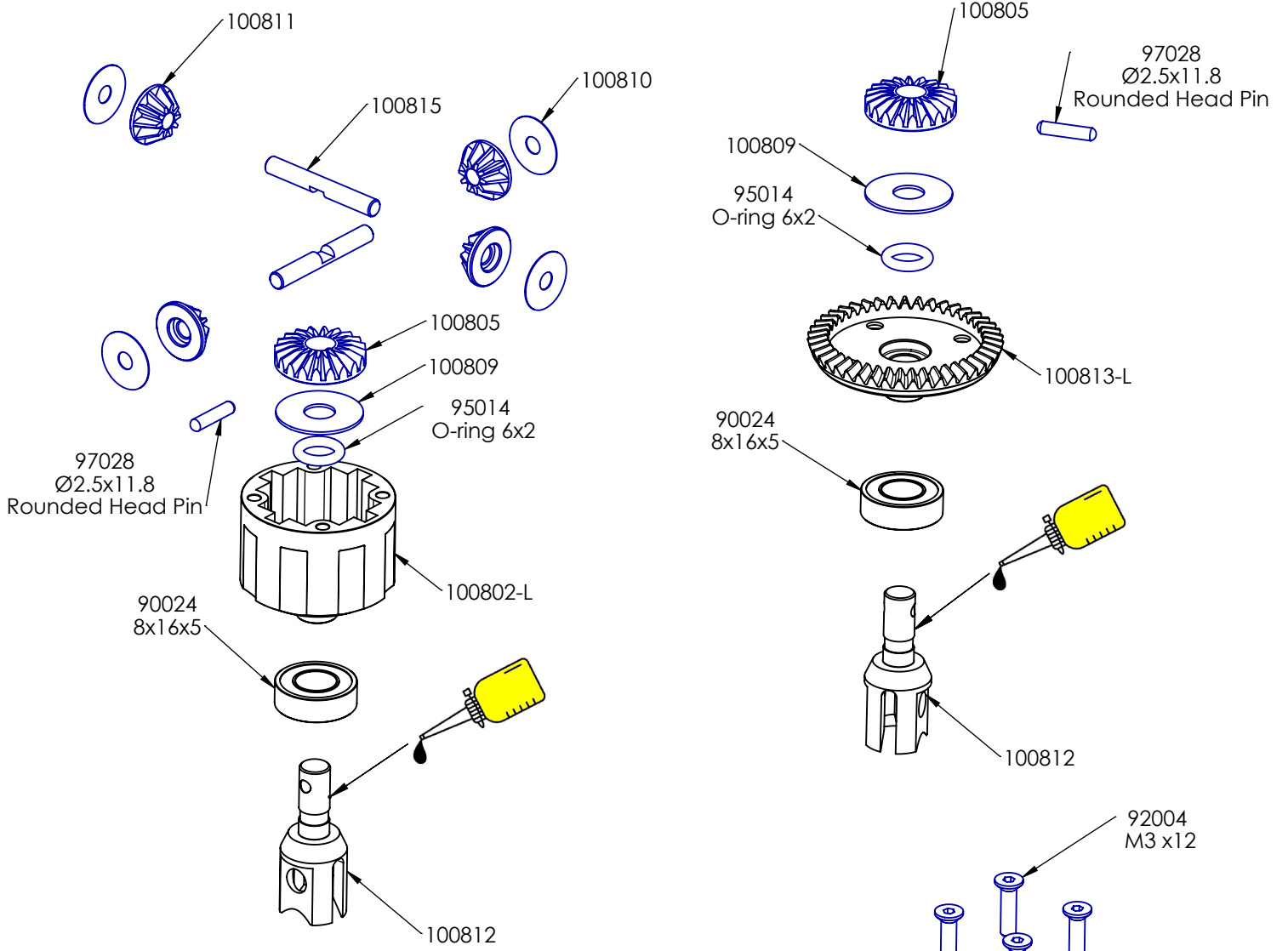

DIFFERENTIAL OIL :
Rear : 20000 cst
Weight : 3 g

Fill the differential up to the top of the pin.
DO NOT fill the diff. to the top of the housing.

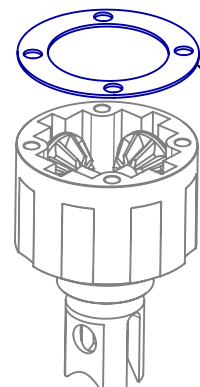
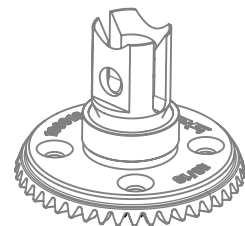
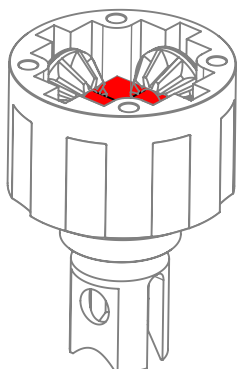

100804-05
OPTIONAL
100804-01 (0.1mm)
100804-02 (0.2mm)

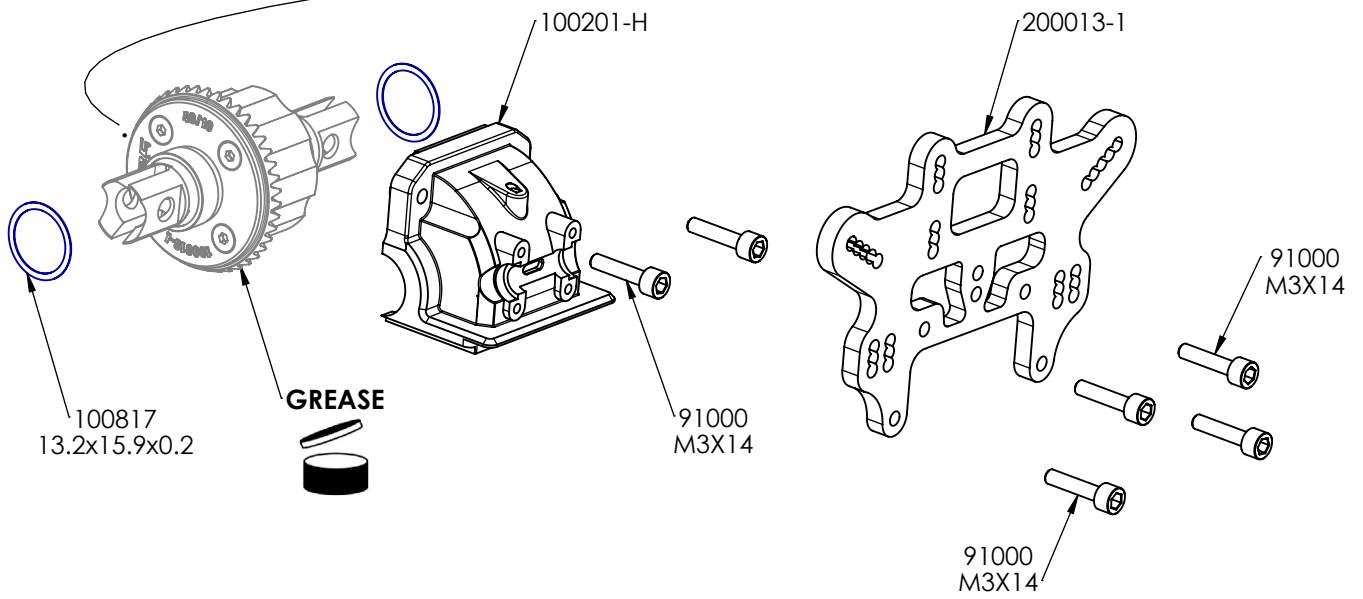
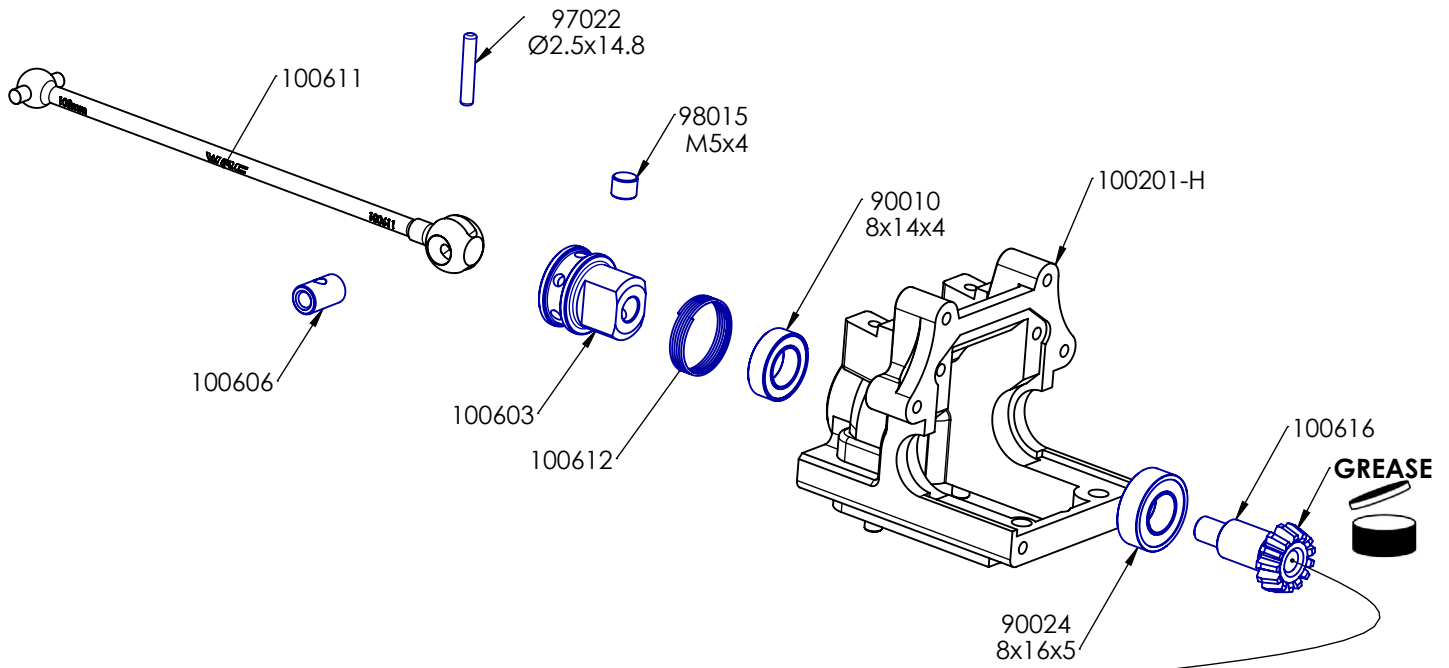
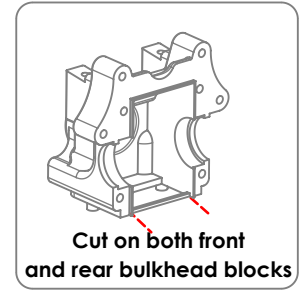

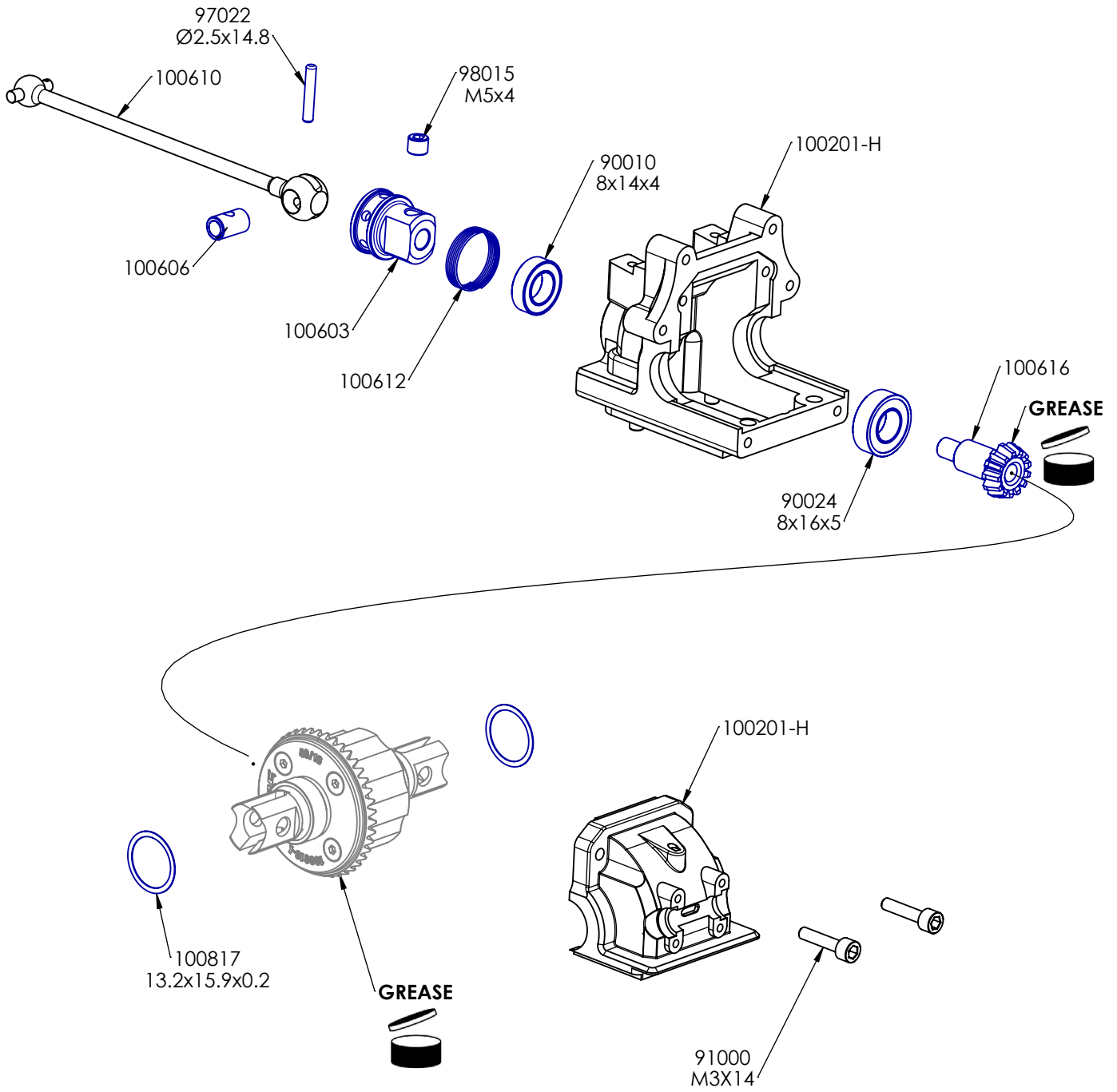
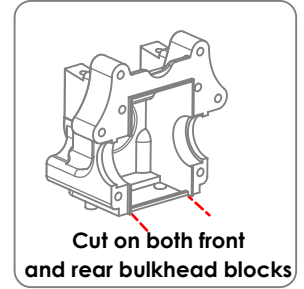

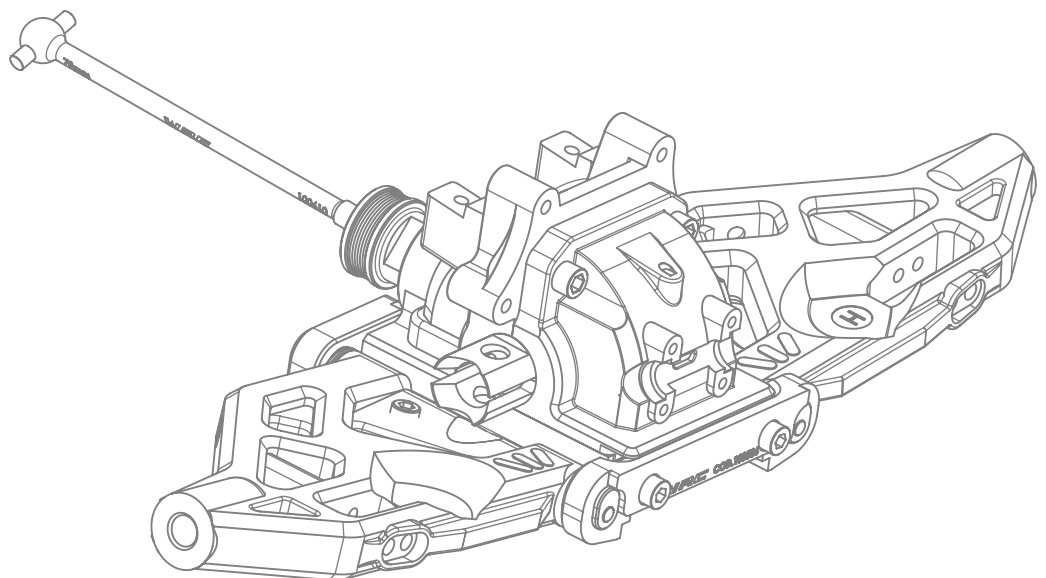
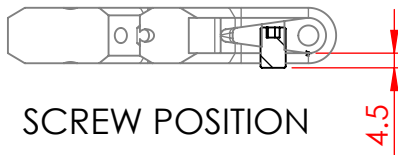
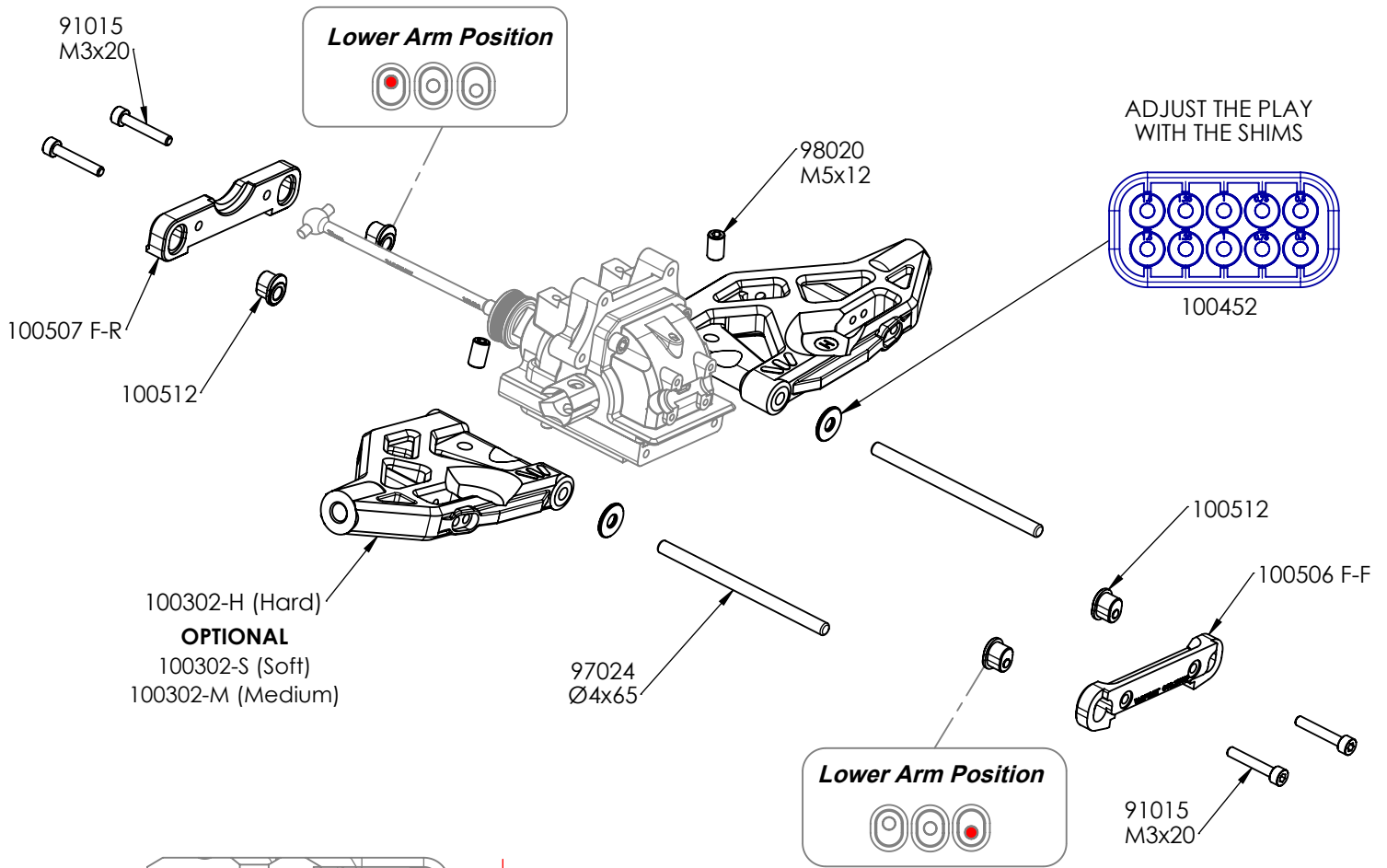

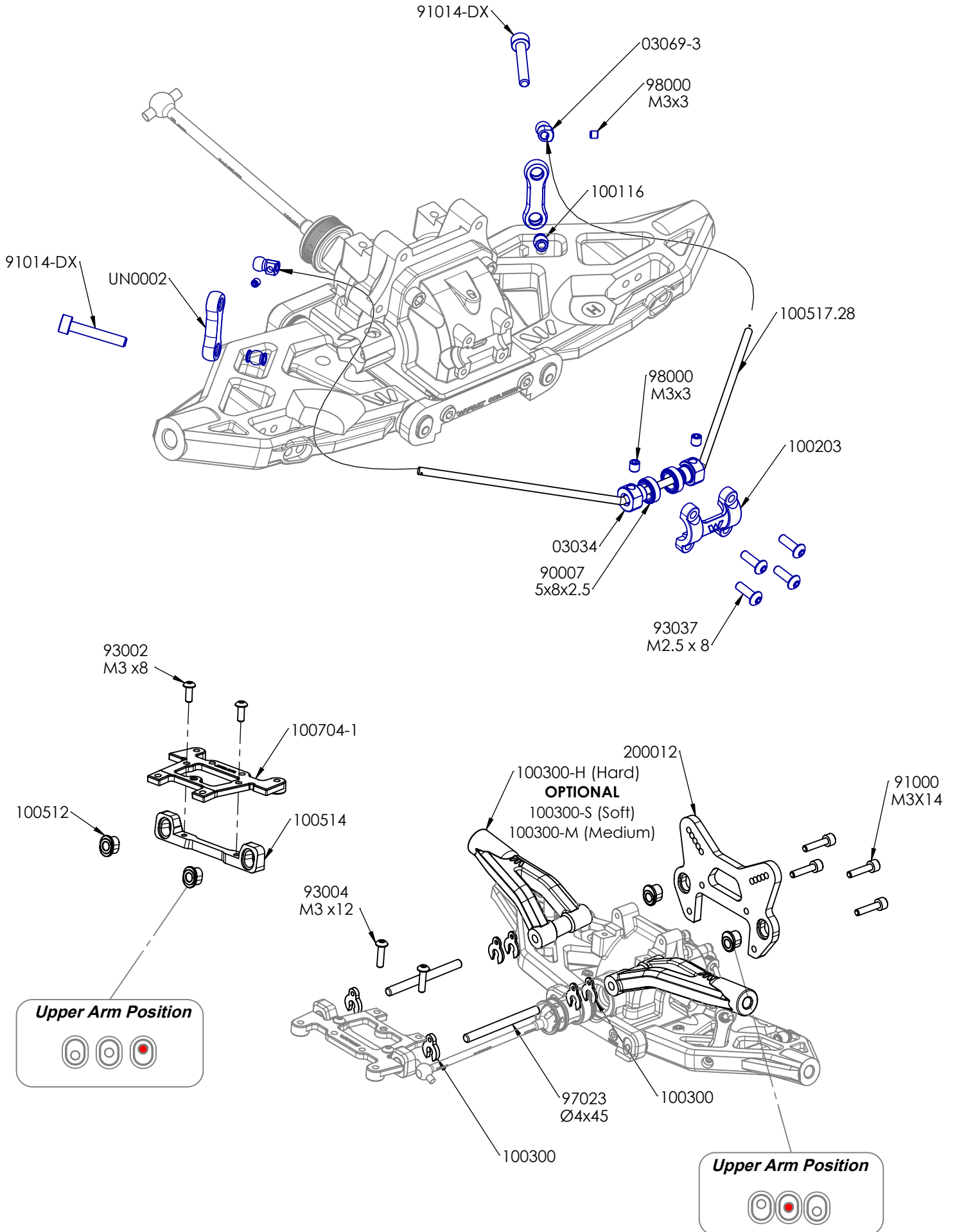

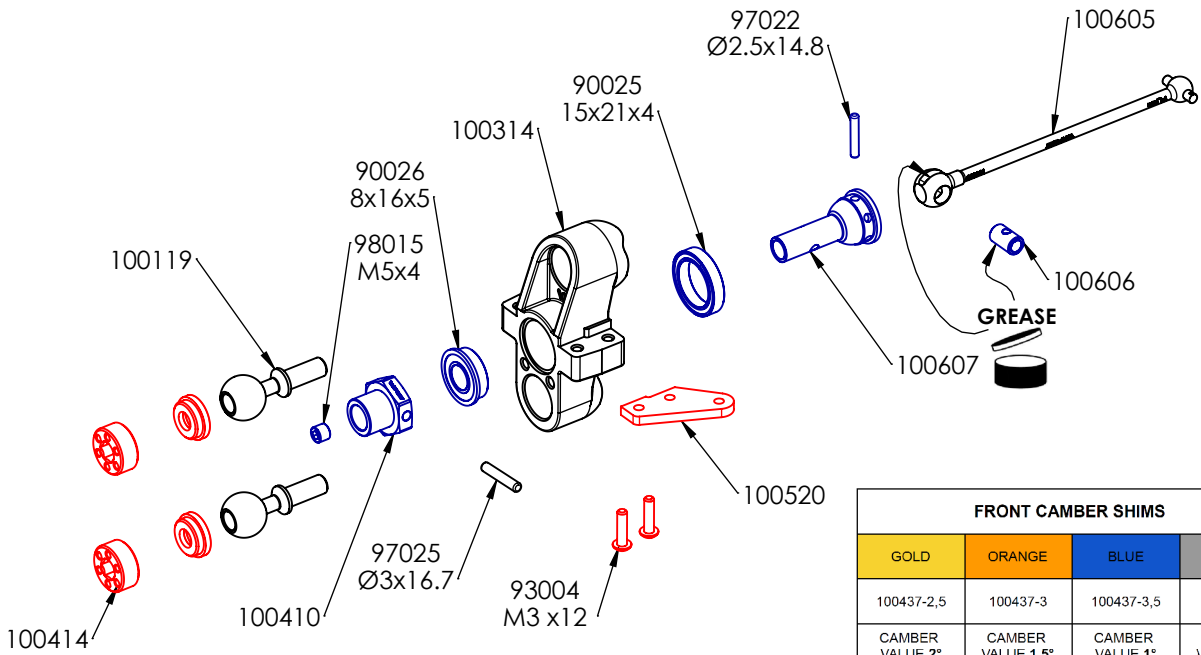
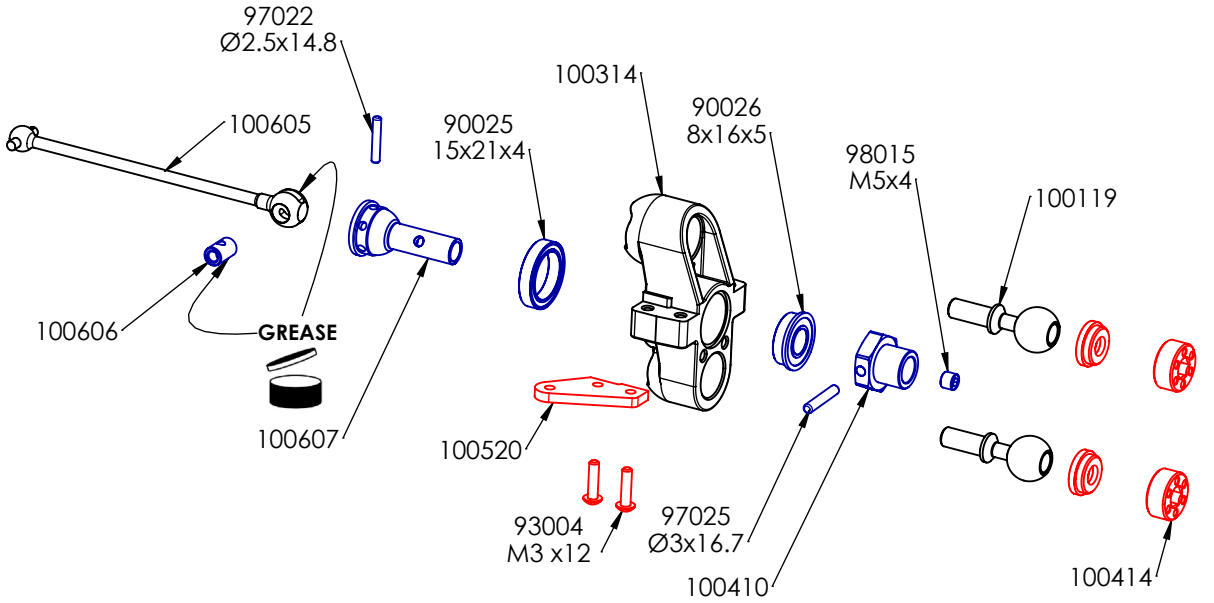

FRONT CAMBER SHIMS			
GOLD	ORANGE	BLUE	GREY
100437-2.5	100437-3	100437-3.5	100437-4
CAMBER VALUE 2°	CAMBER VALUE 1.5°	CAMBER VALUE 1°	CAMBER VALUE 0.5°

100437-3.5 (3.5mm)
OPTIONAL
 100437-2.5 (2.5mm)
 100437-3 (3mm)
 100437-4 (4mm)

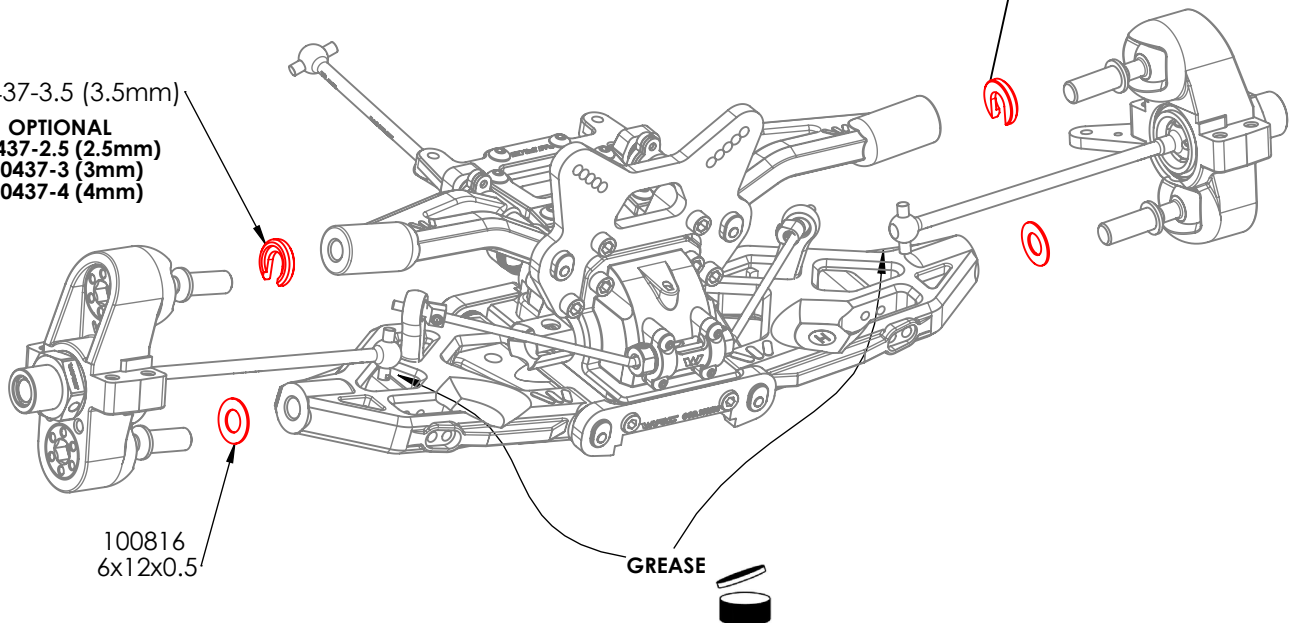

Lower Arm Position

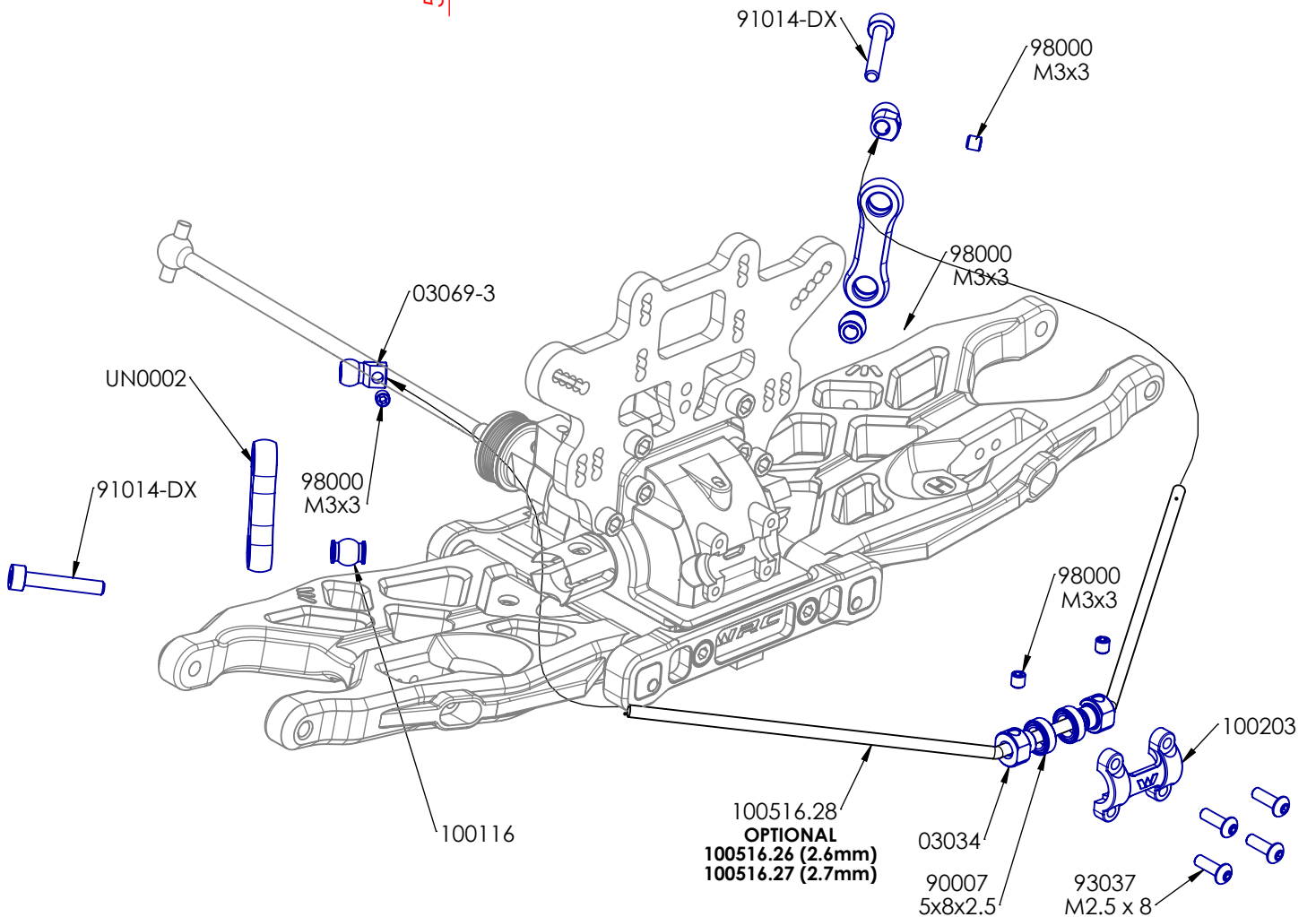
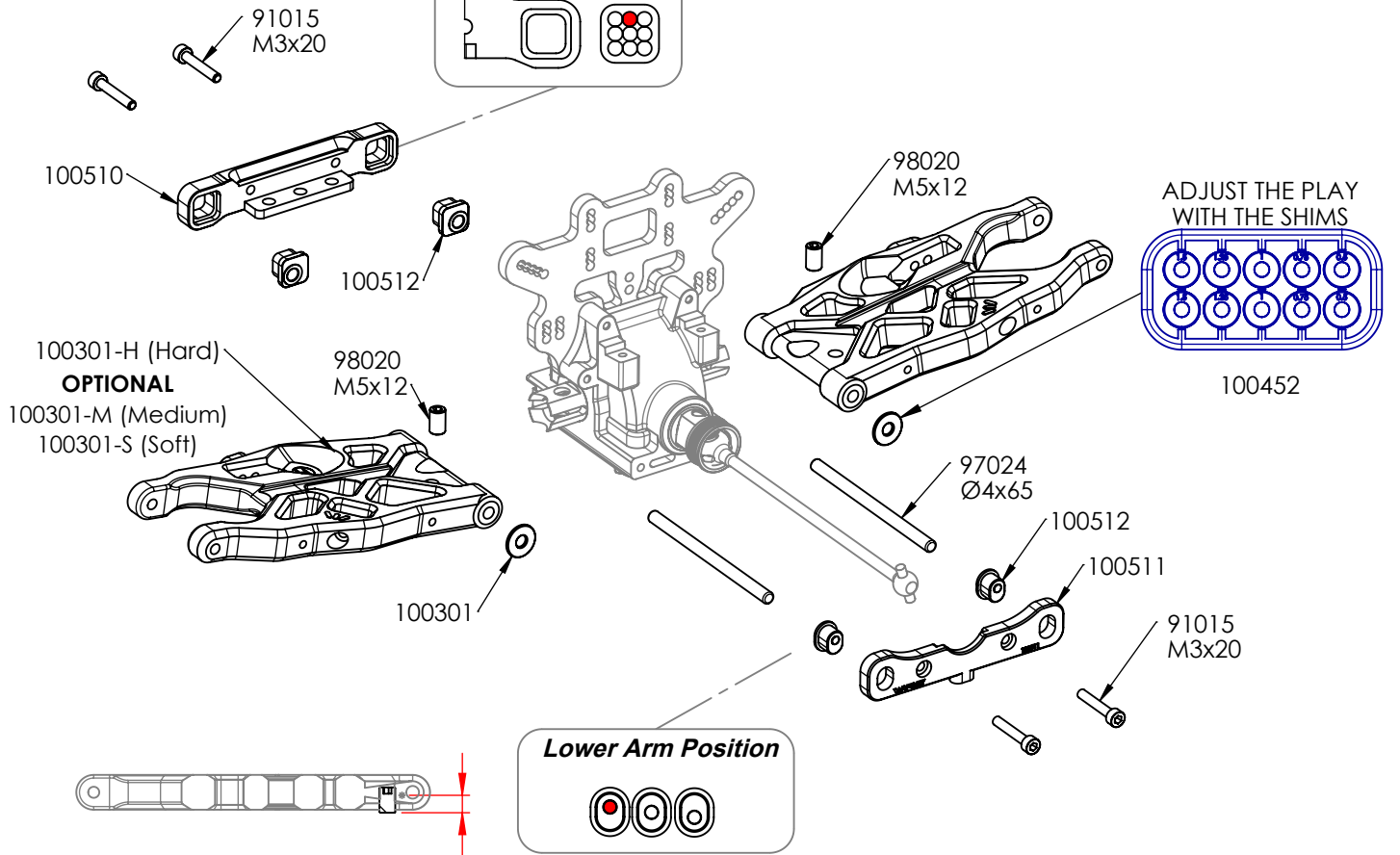

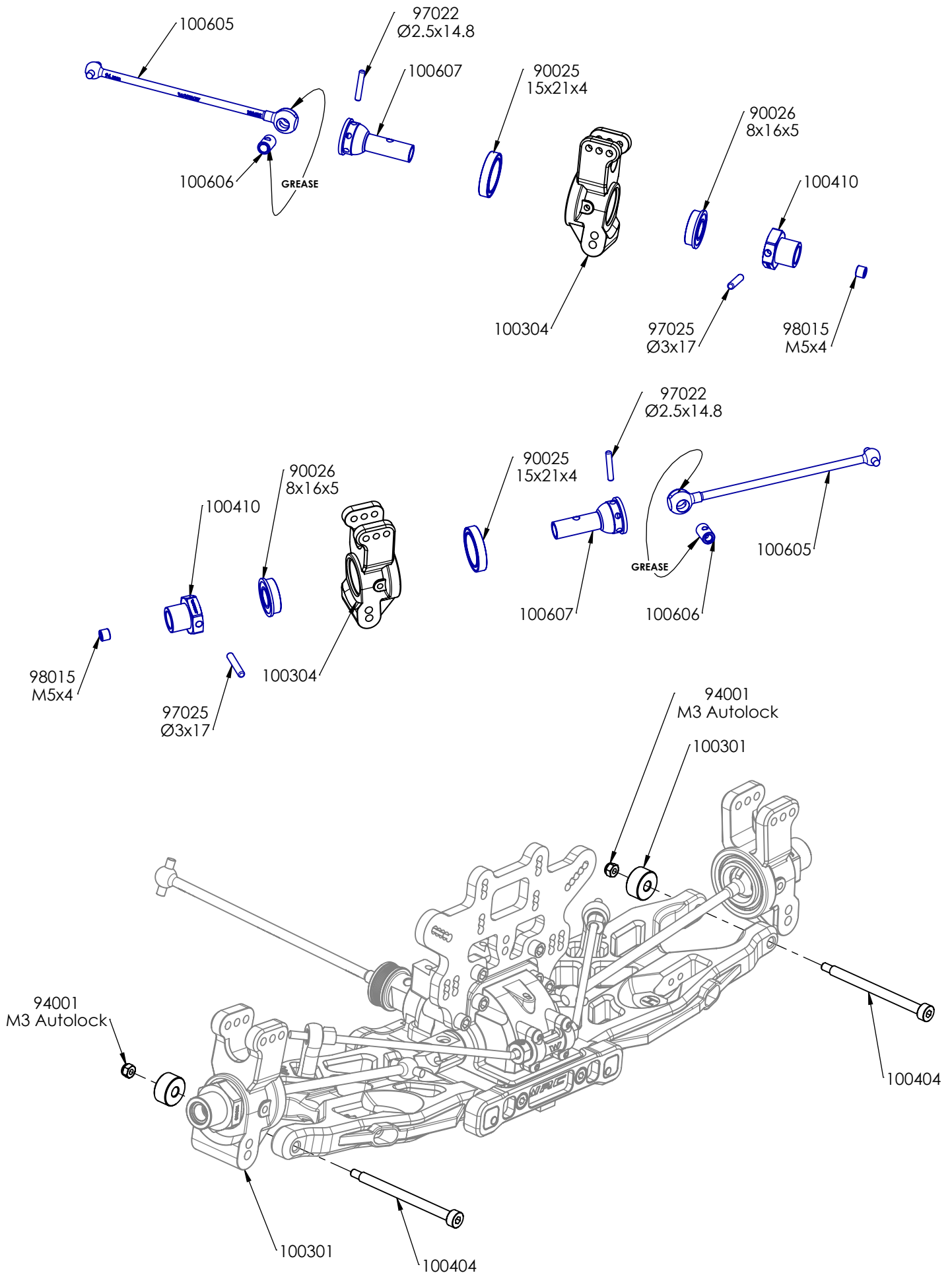

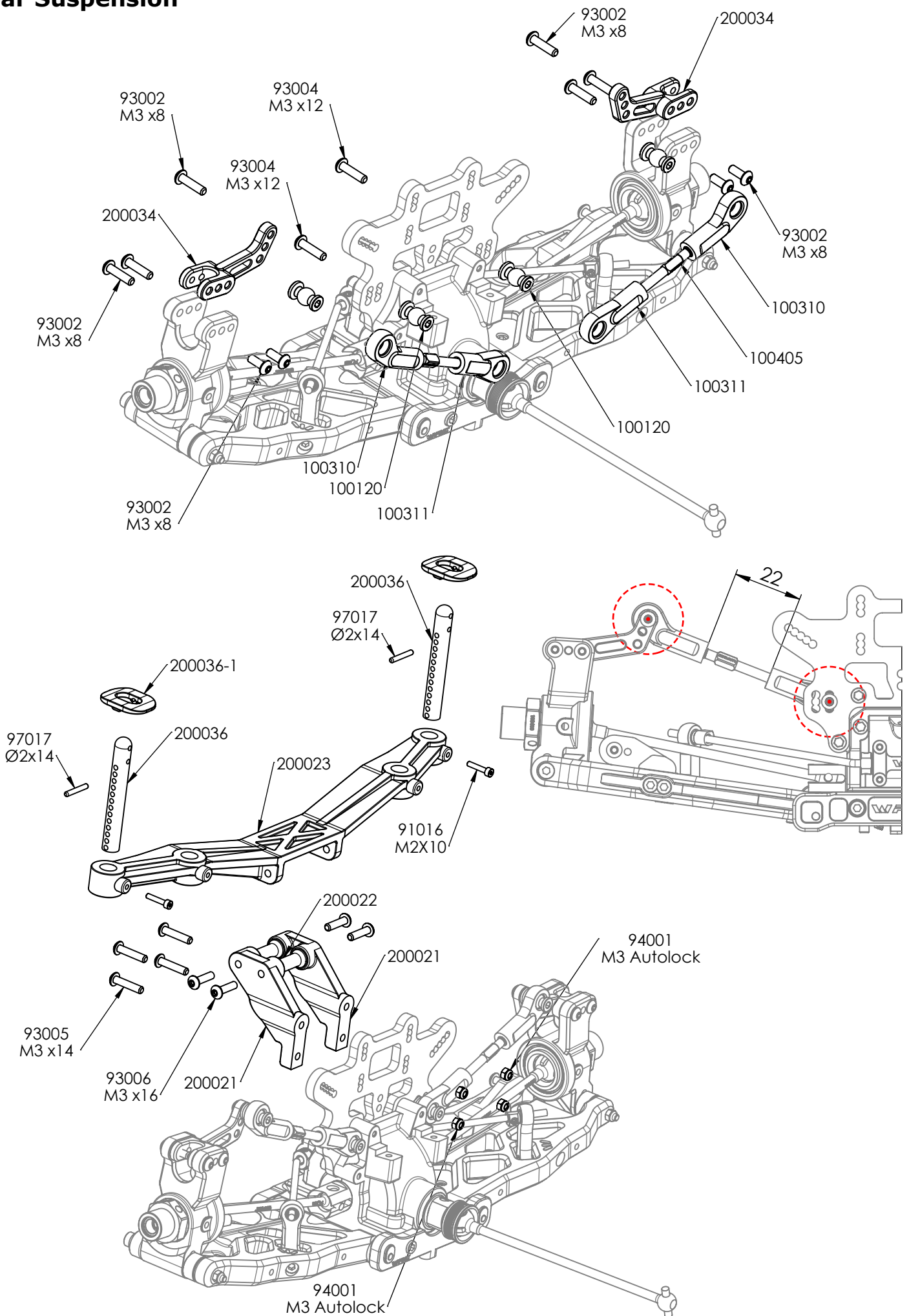

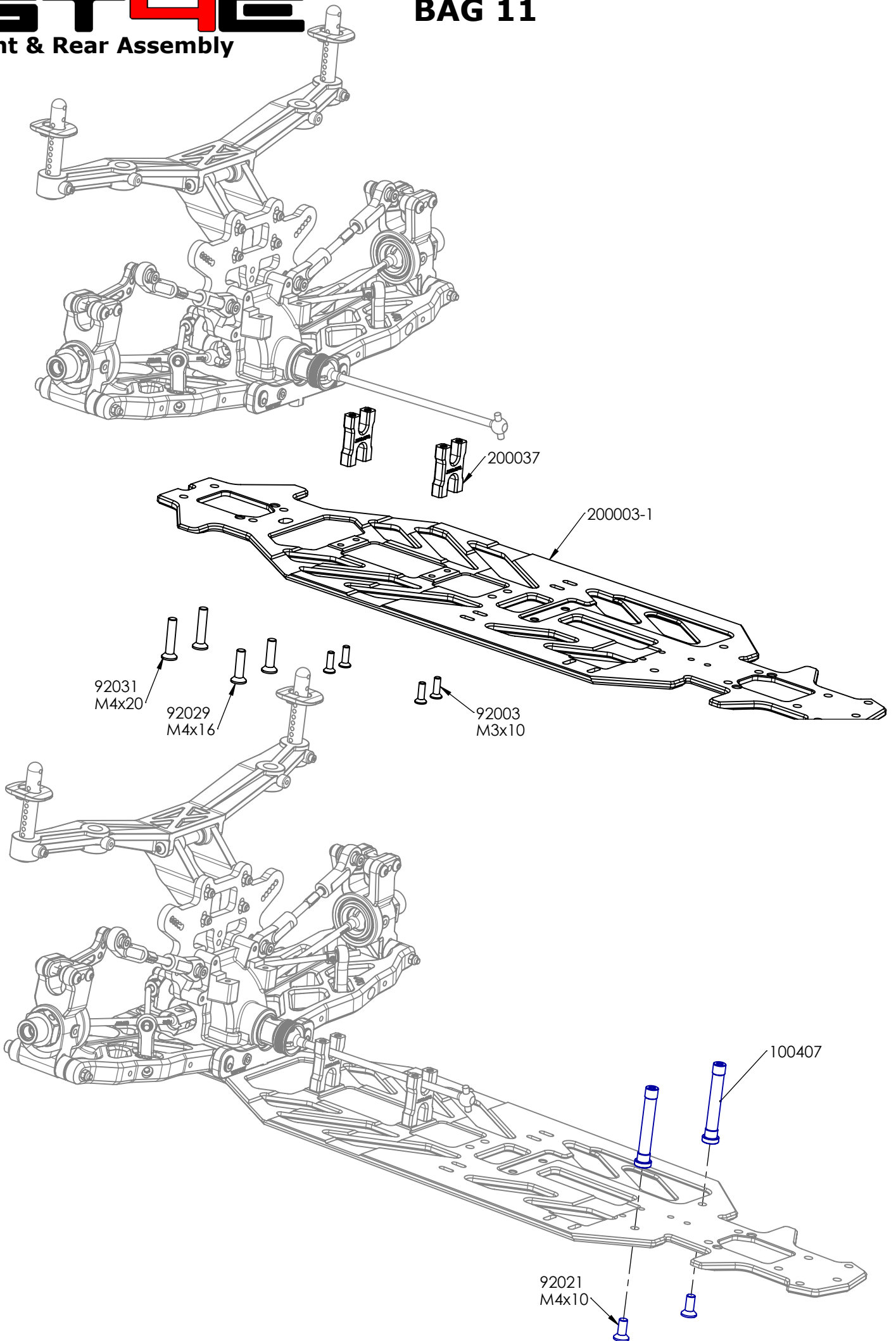

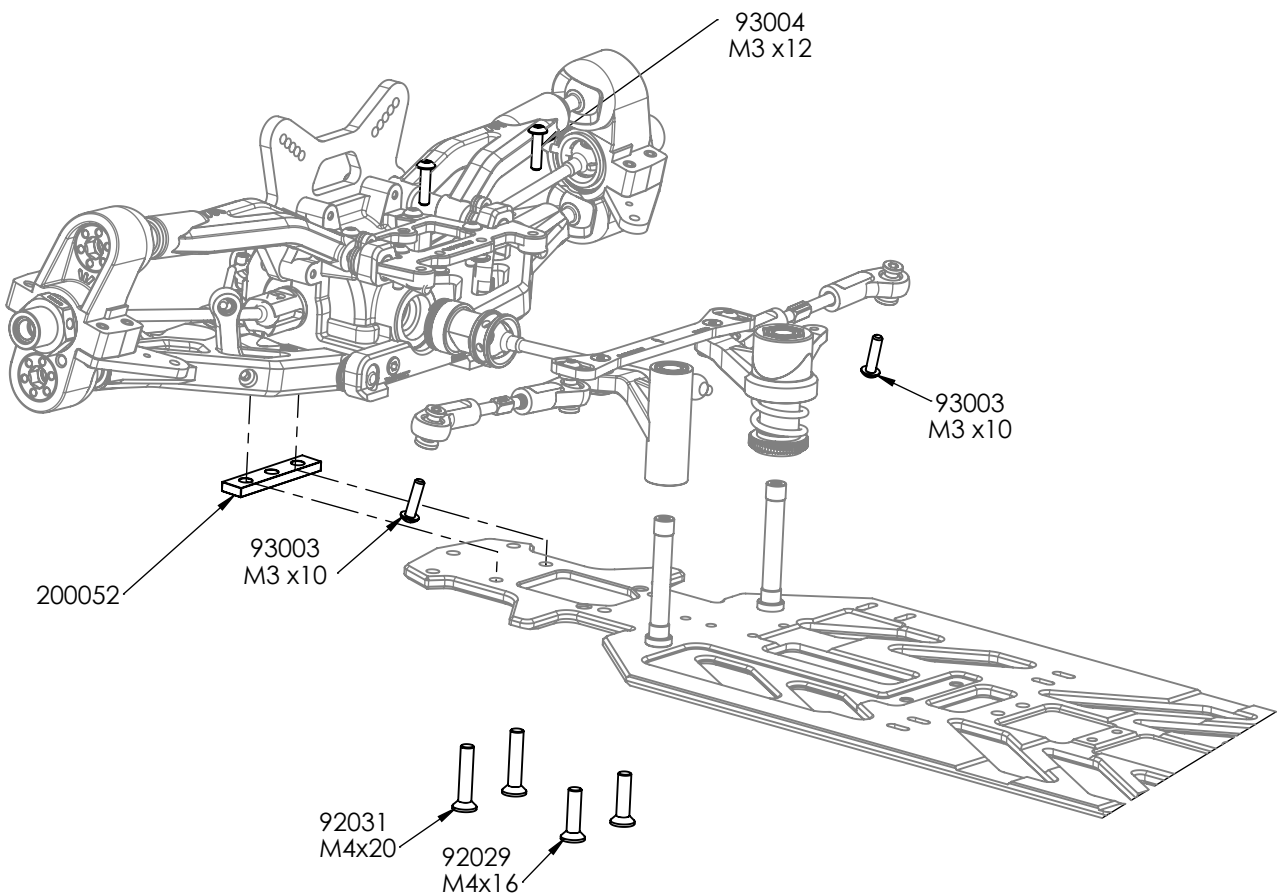
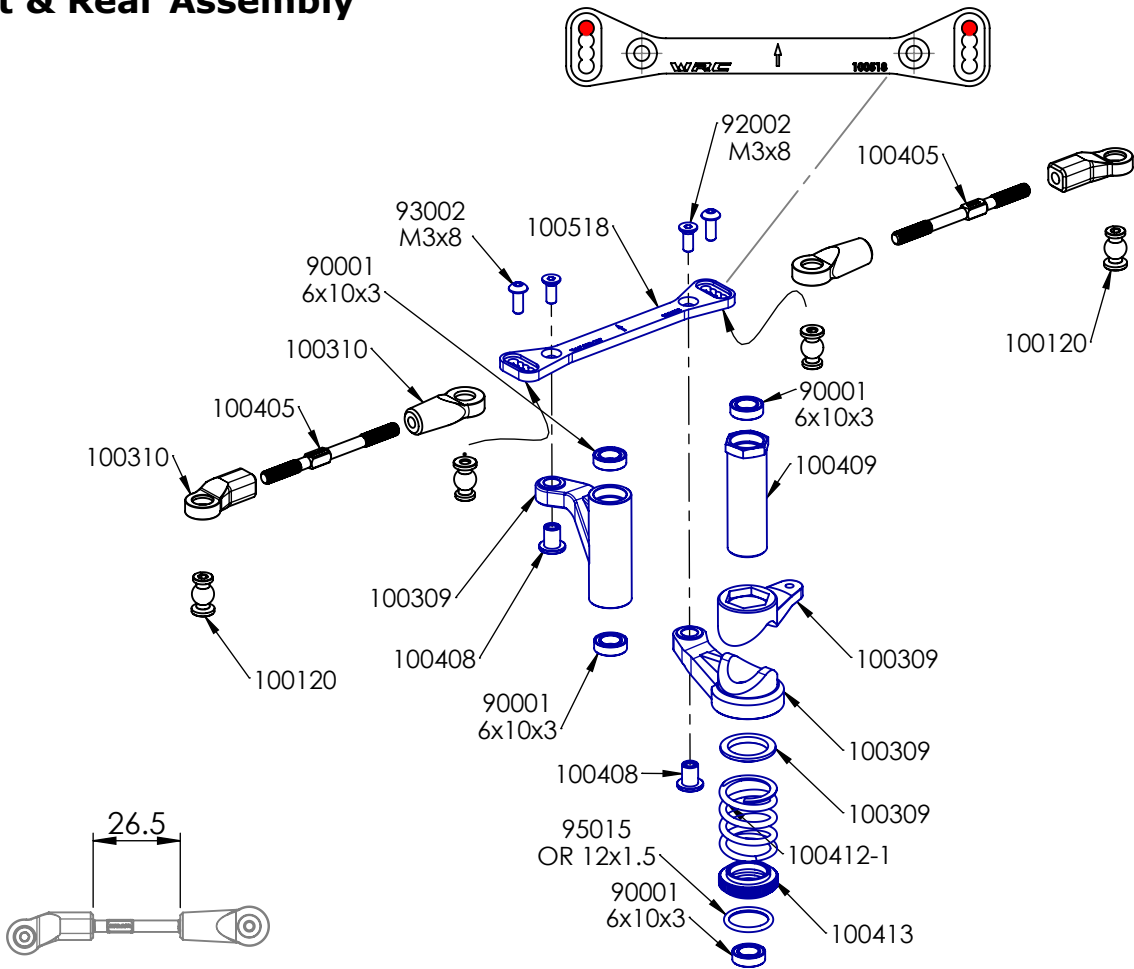

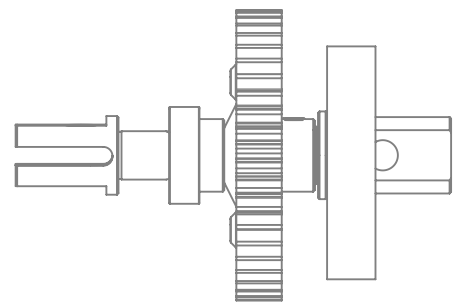
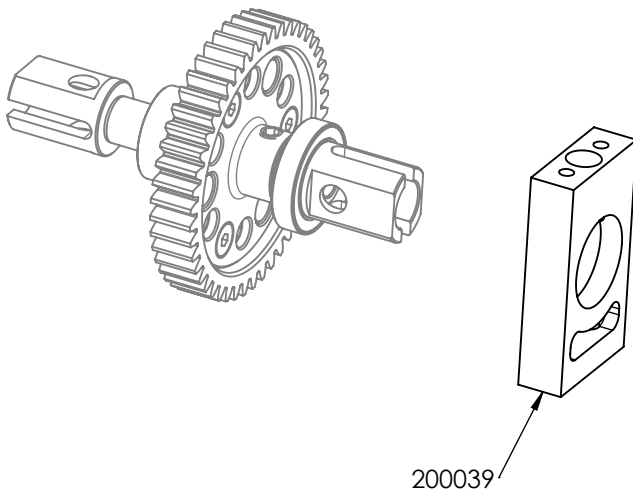
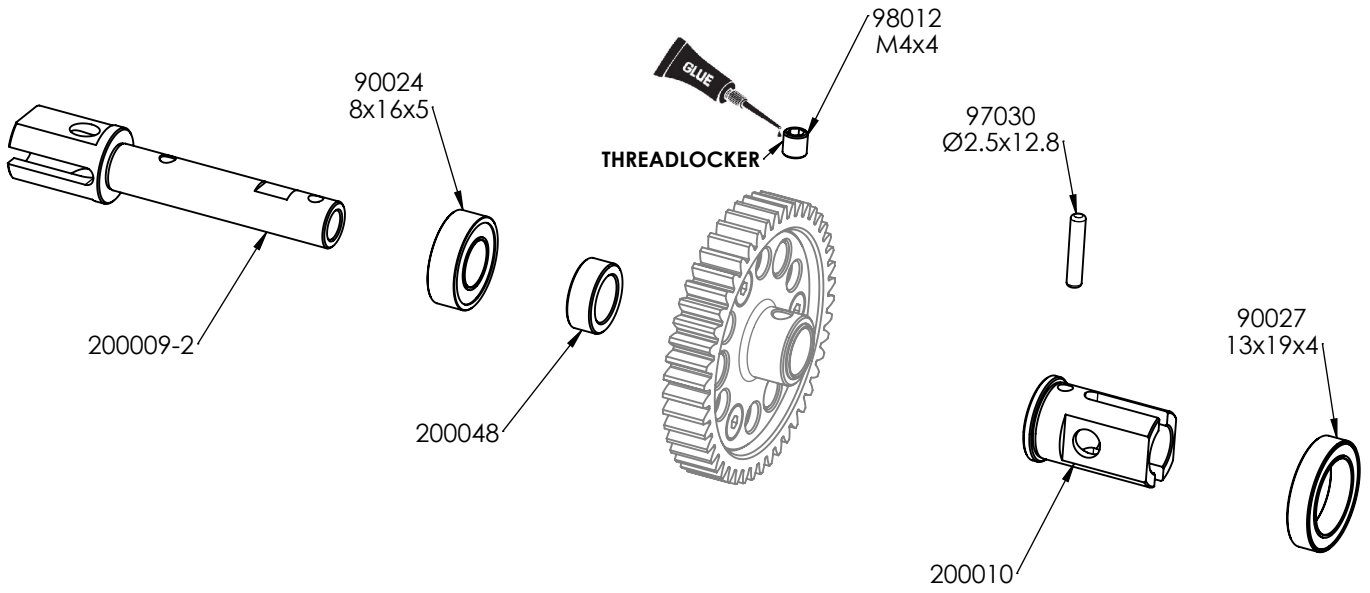
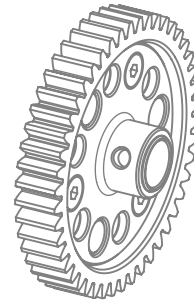
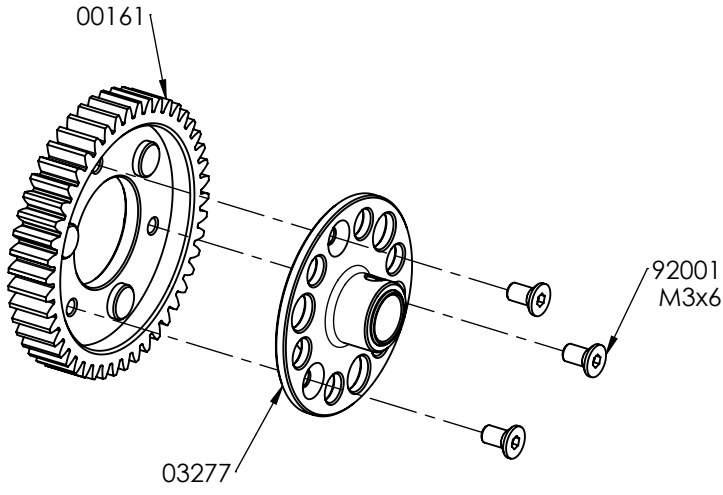

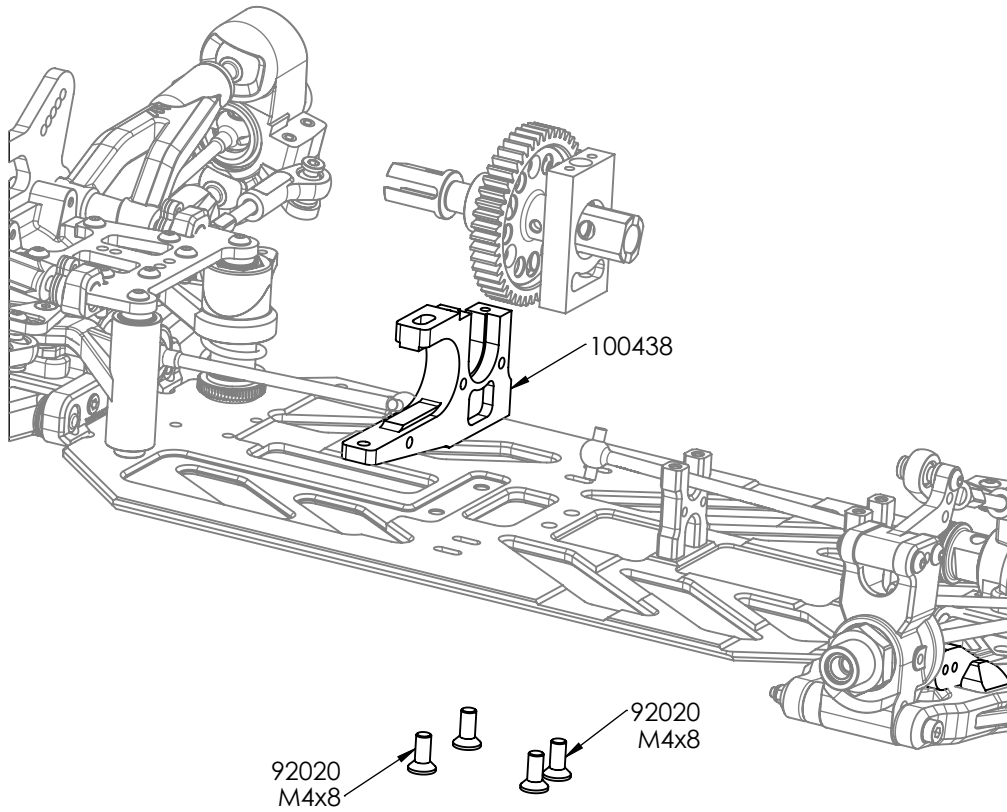

Electric motor

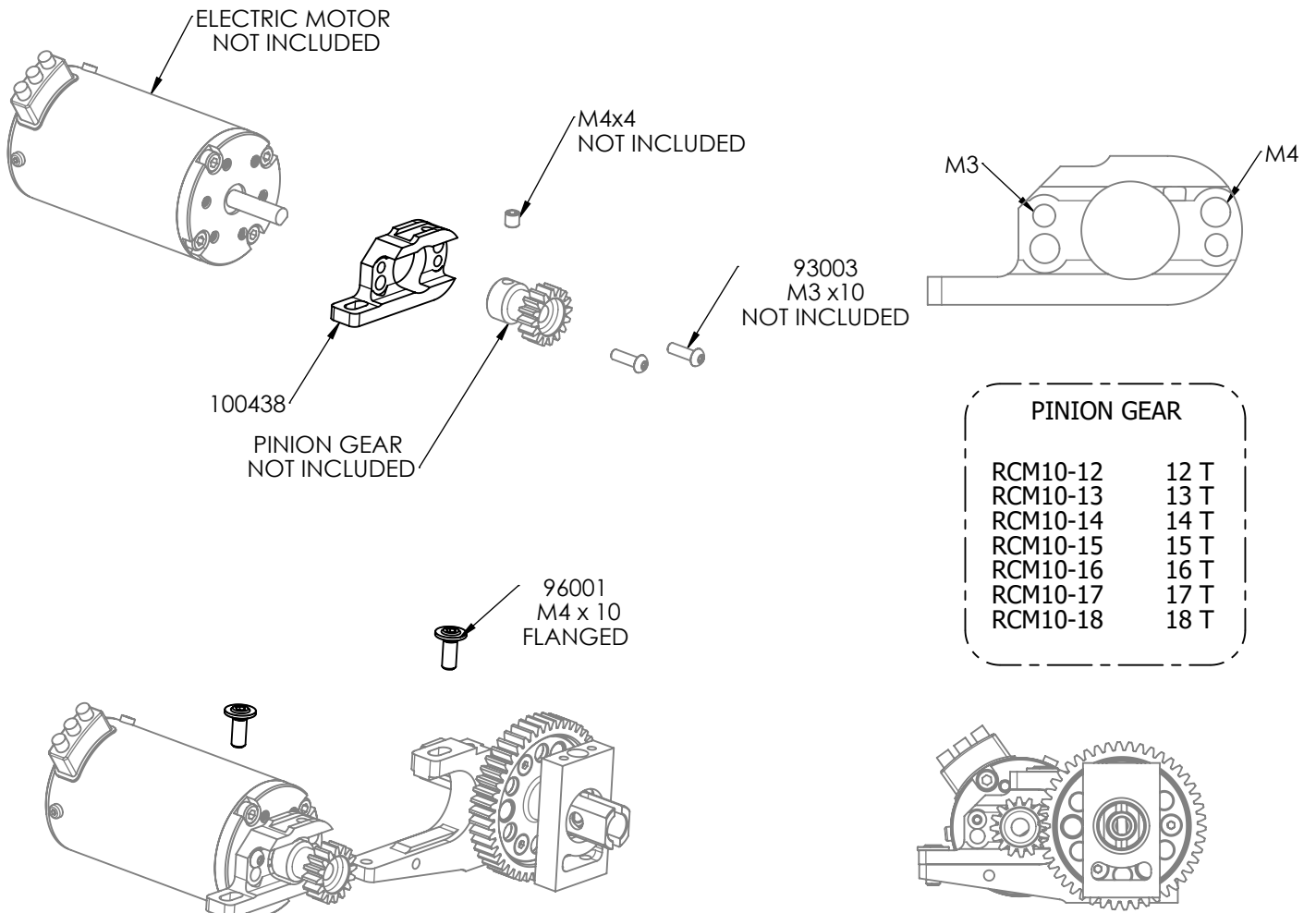

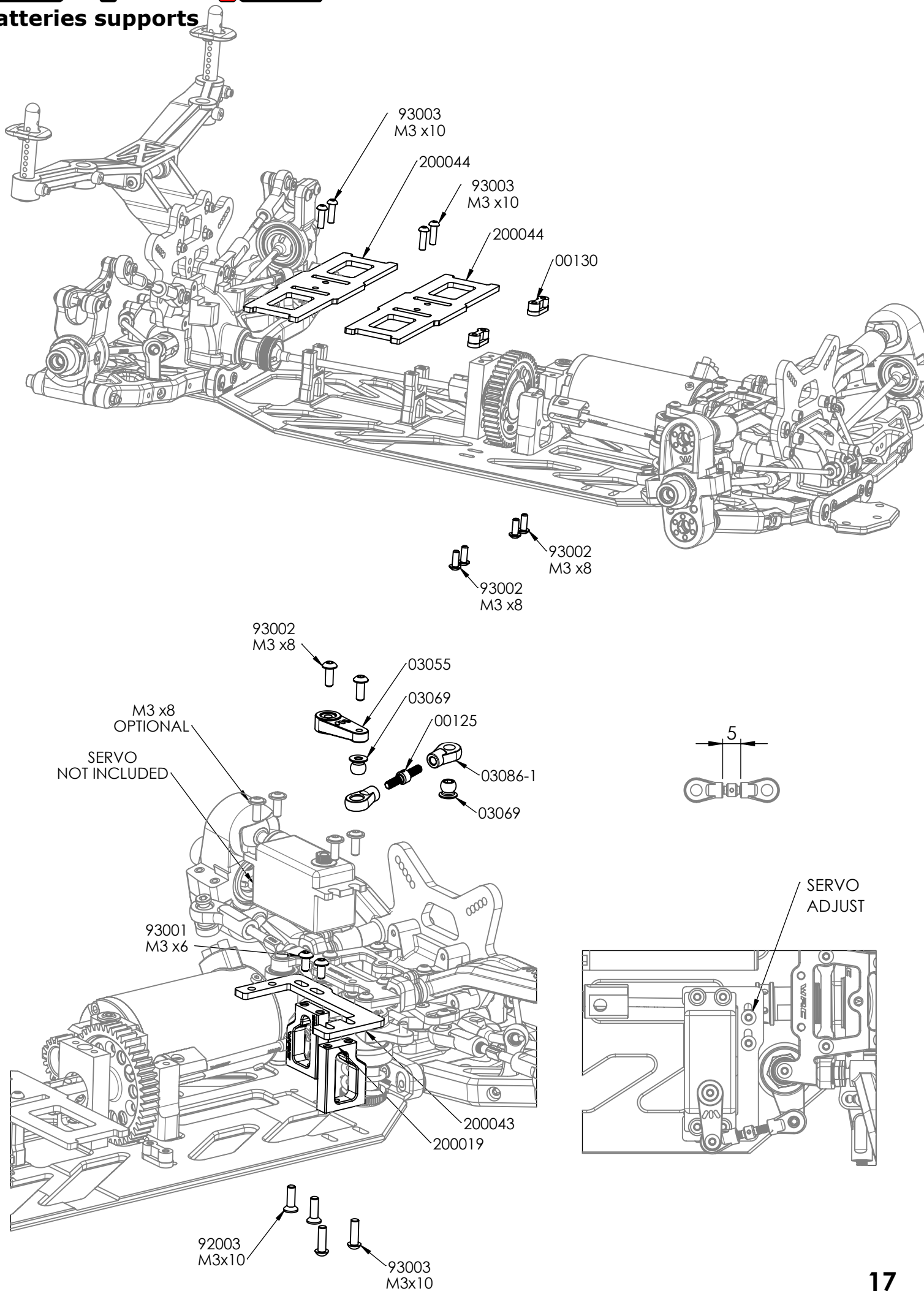

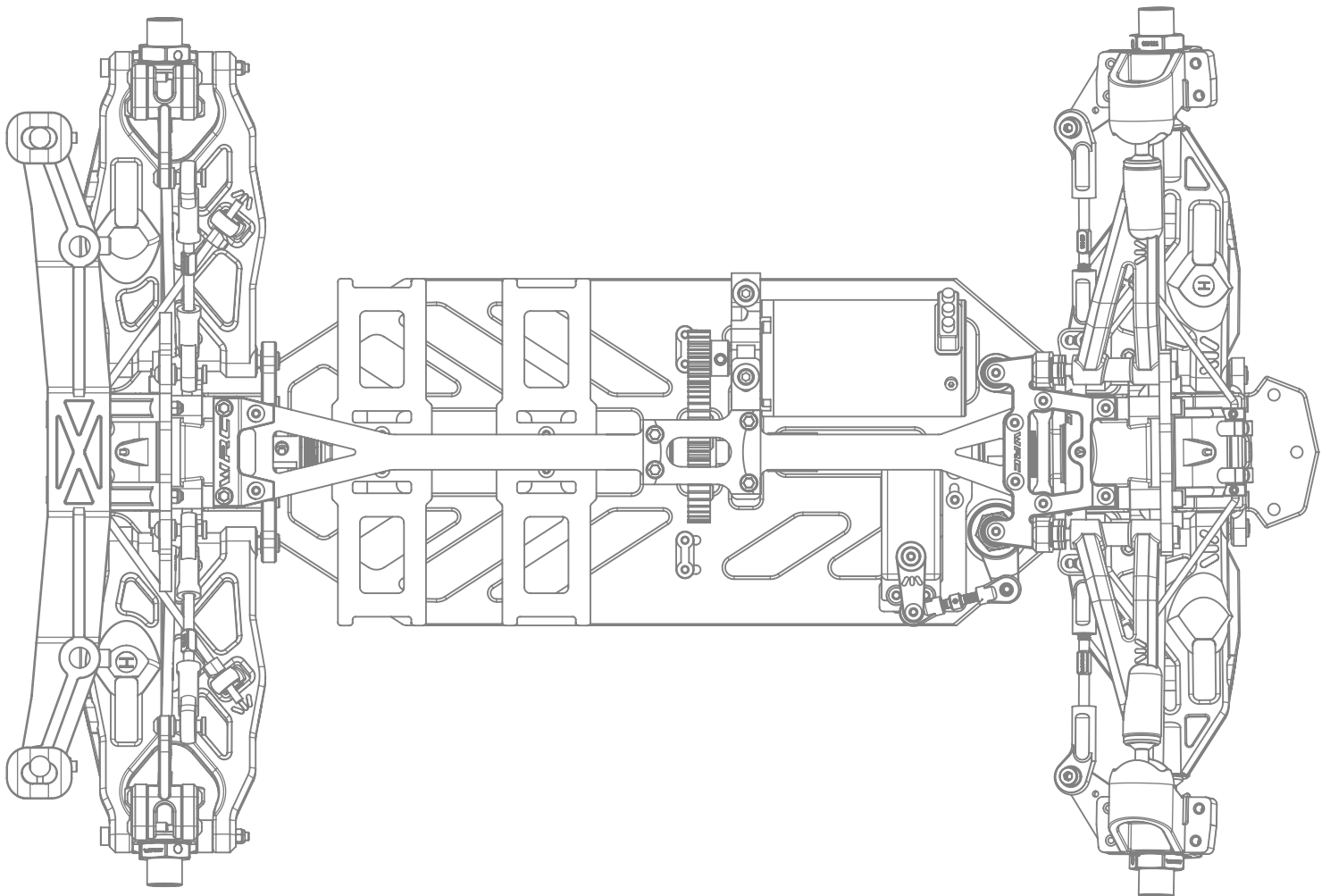
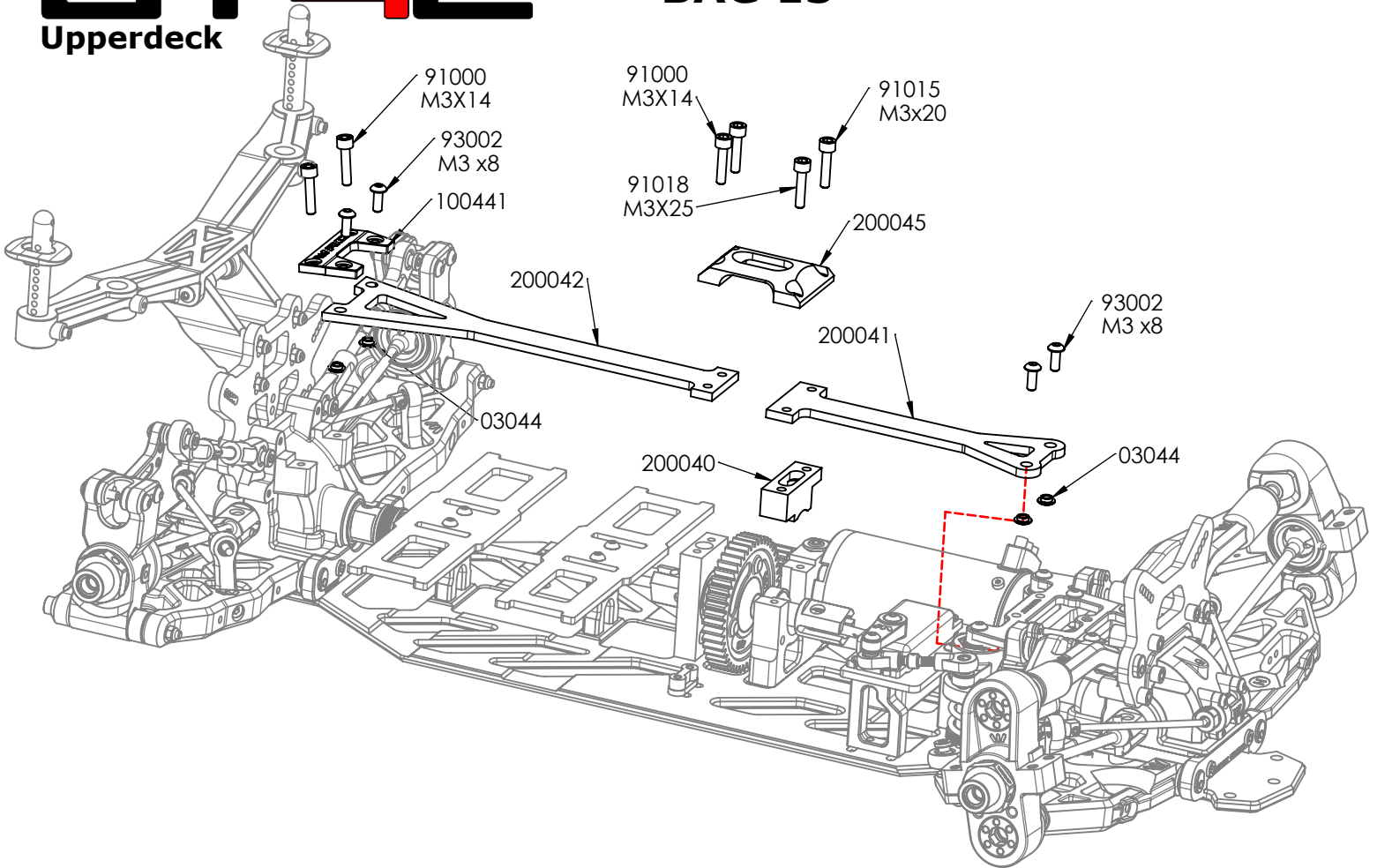

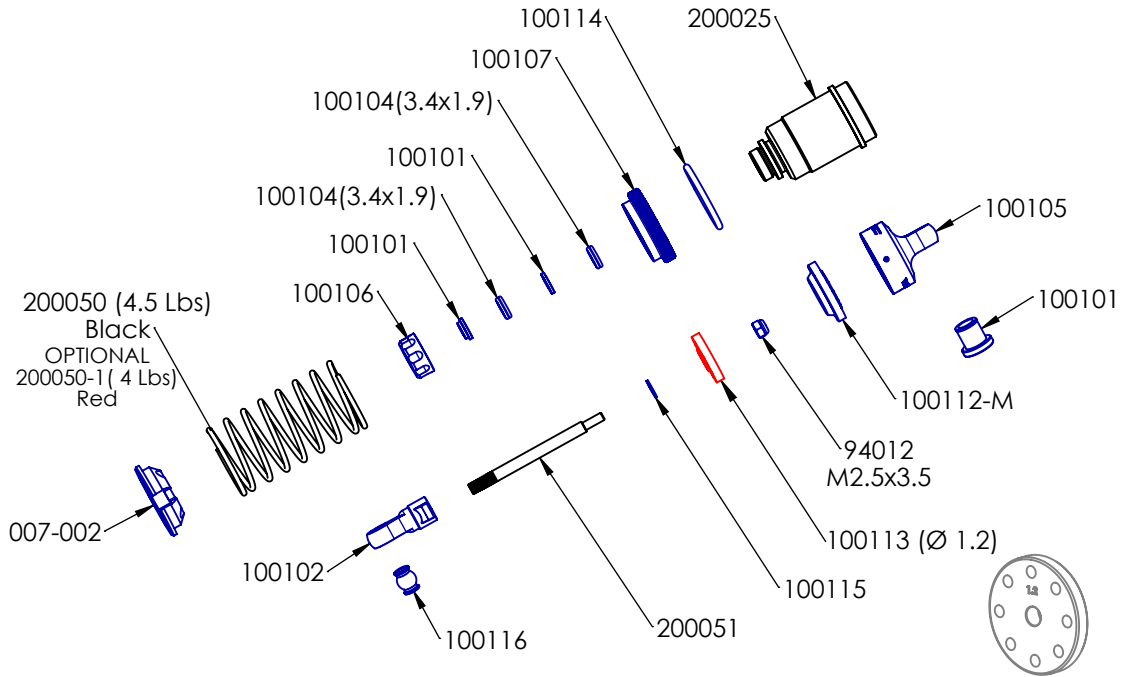

ASSEMBLY 4 SETS

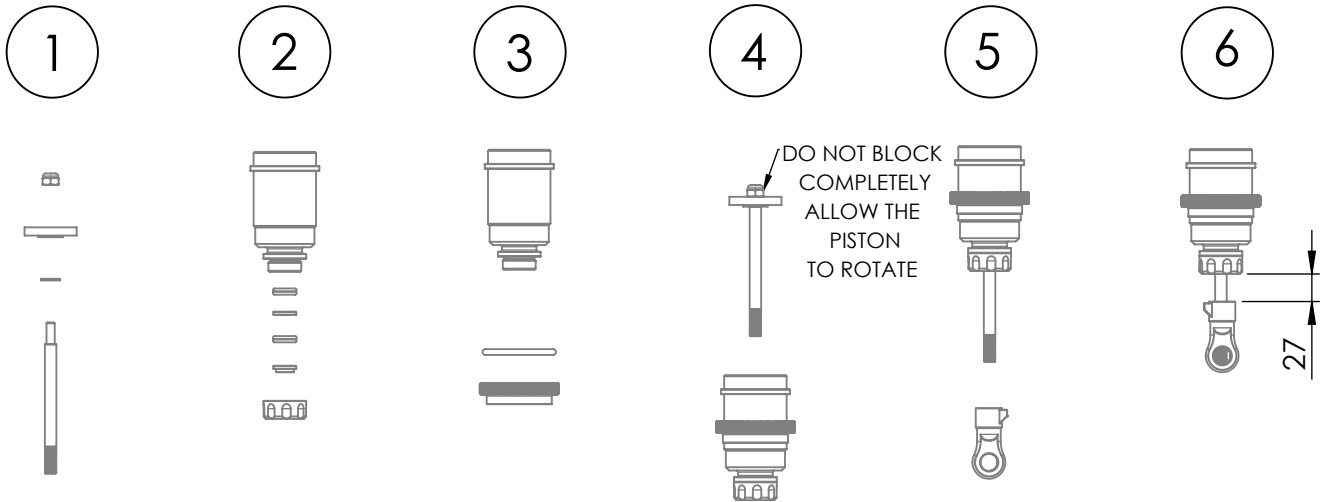

7



SHOCK FILLING

Fully extend the piston rod so the piston is at the bottom of the shock body.

Hold the shock upright and fill the shock body with shock oil as in the picture.

Let the oil settle and allow air bubbles to rise to the top. Slowly move the piston up and down until no more air bubbles appear. Add shock oil as necessary.

Pull the piston rod most of the way out of the shock bod. Let the shock rest for 5 minutes to allow the air bubbles to scape.

8



9

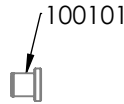

P- ONE SHOCKS OIL	
CODE	CST
SO-400	400
SO-500	500
SO-600	600
SO-700	700
SO-800	800 (IN KIT)

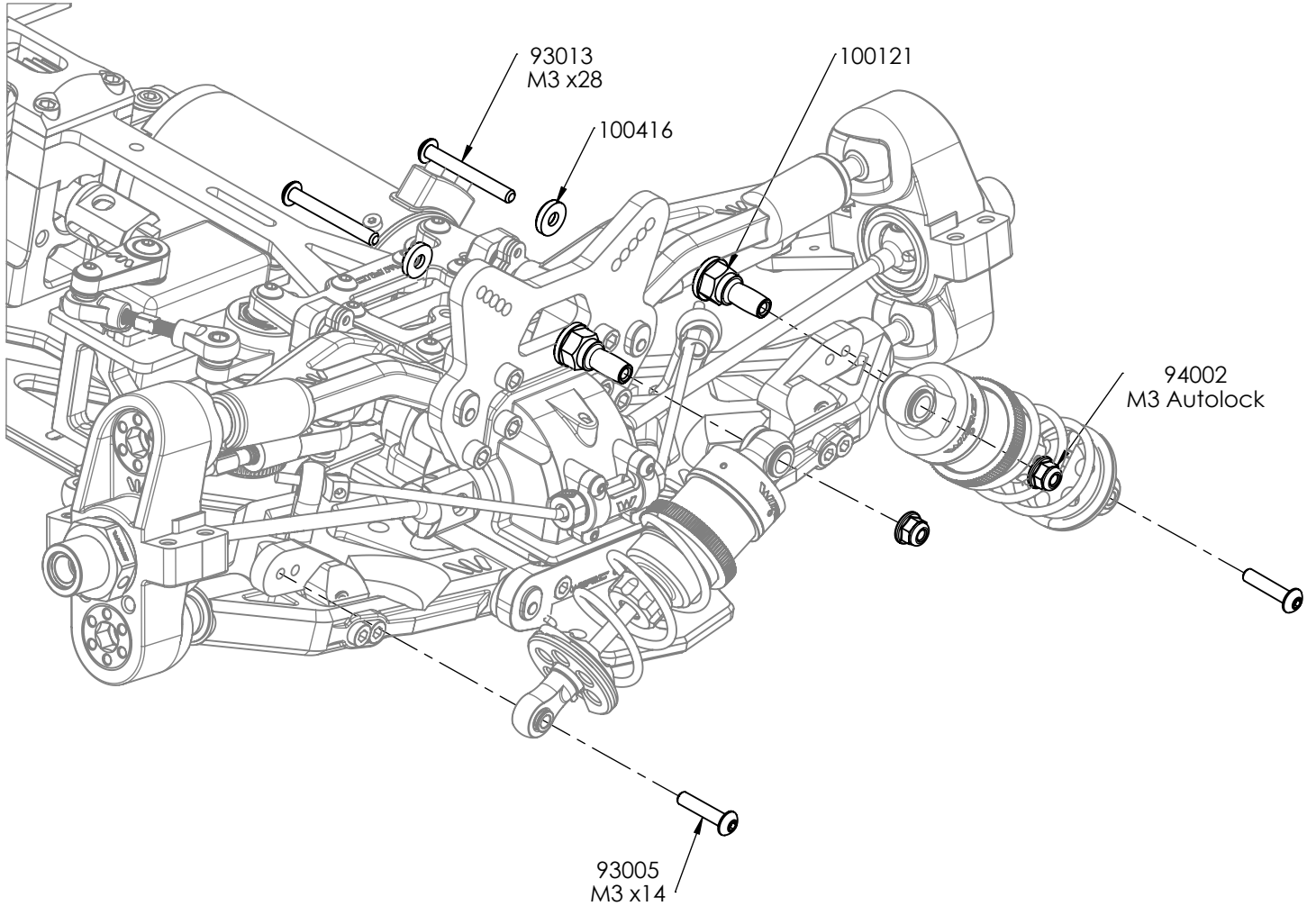
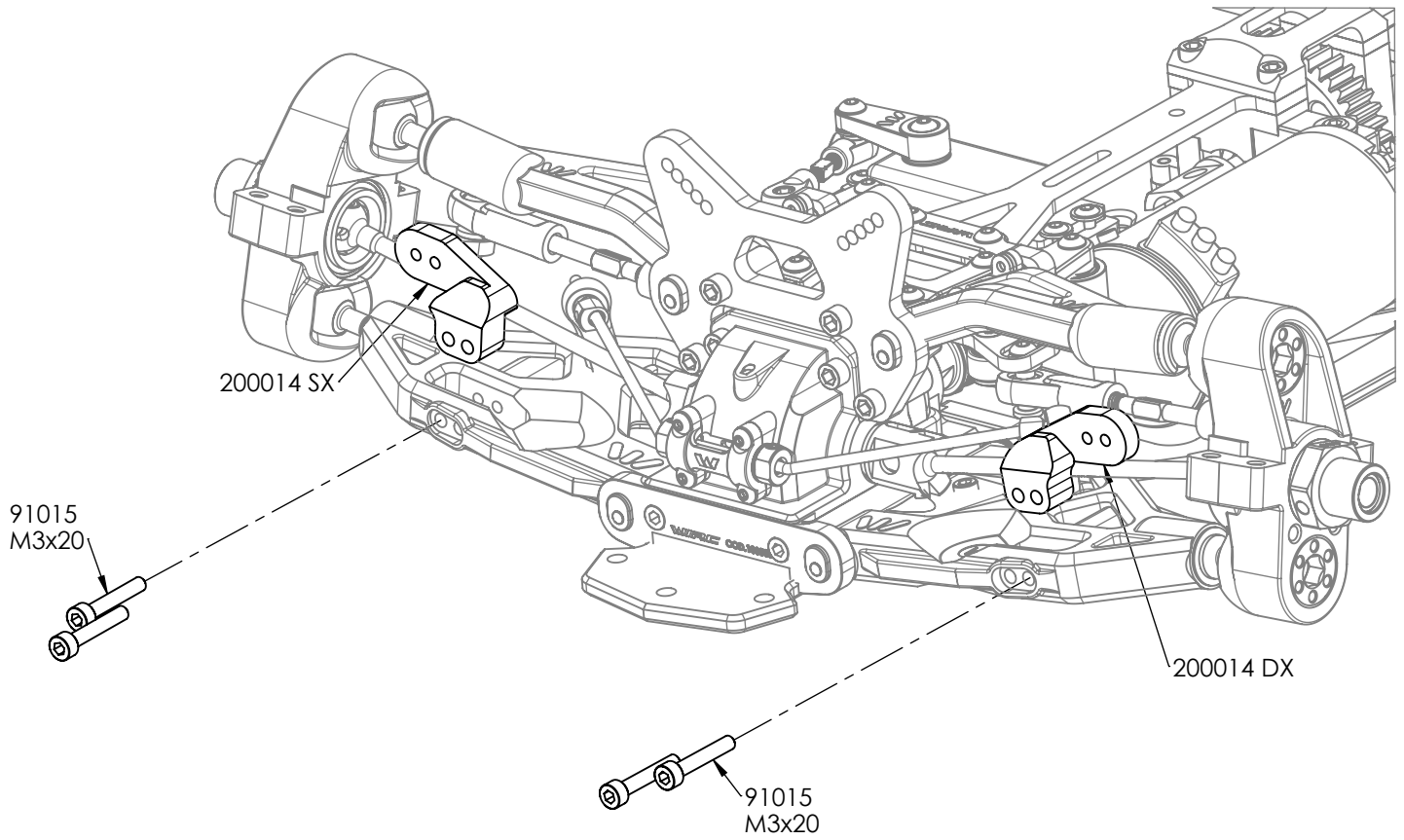

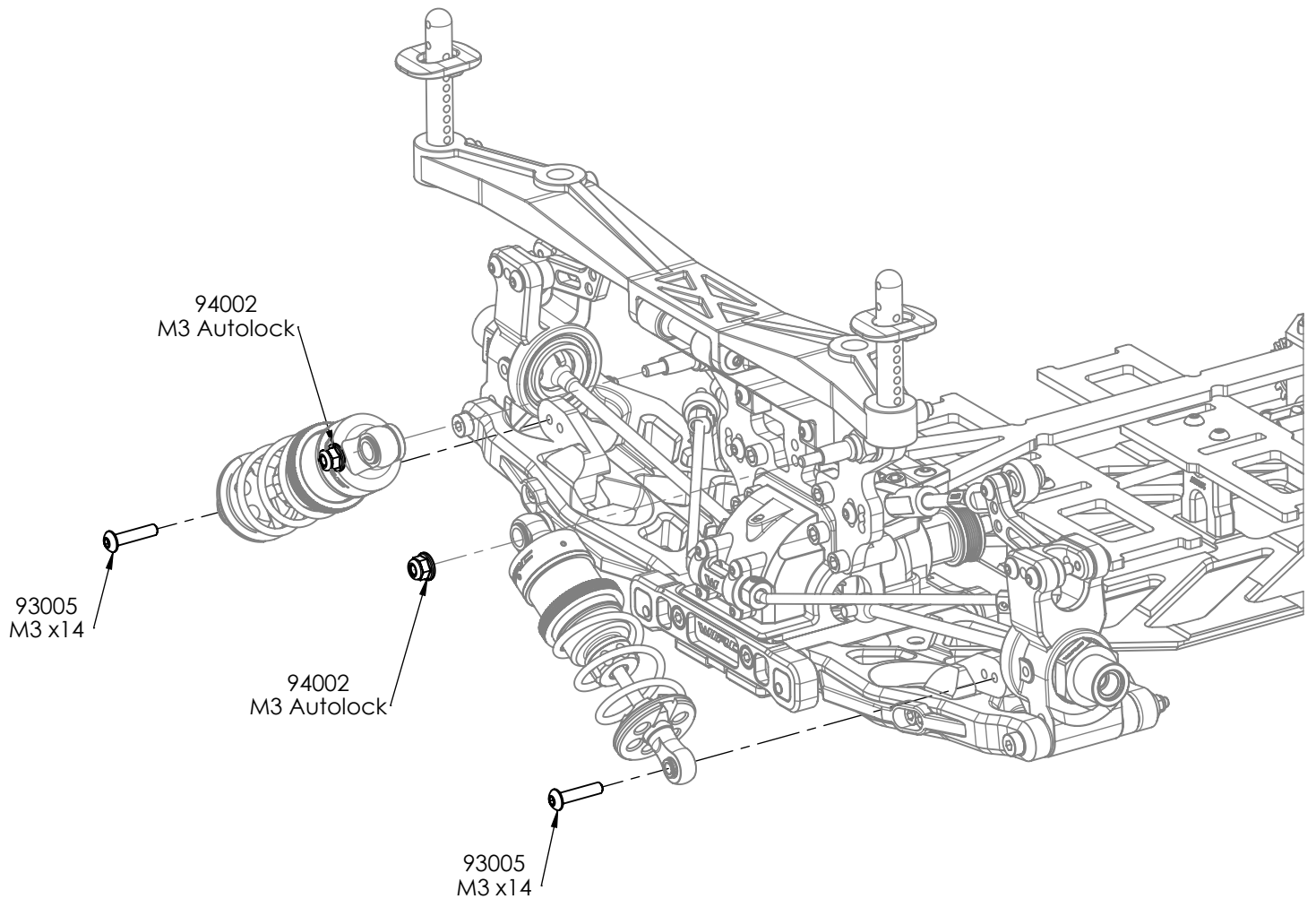
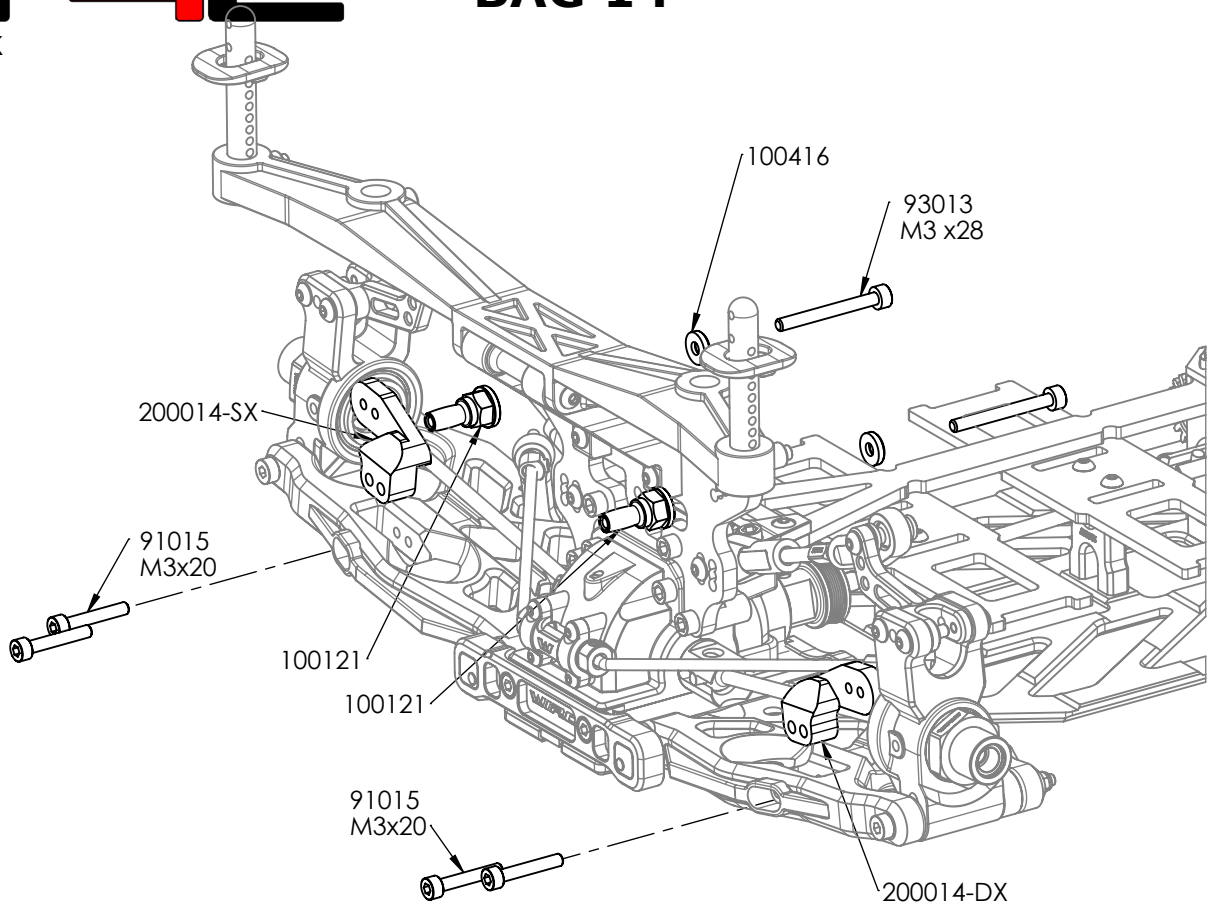

CUT TO SIZE

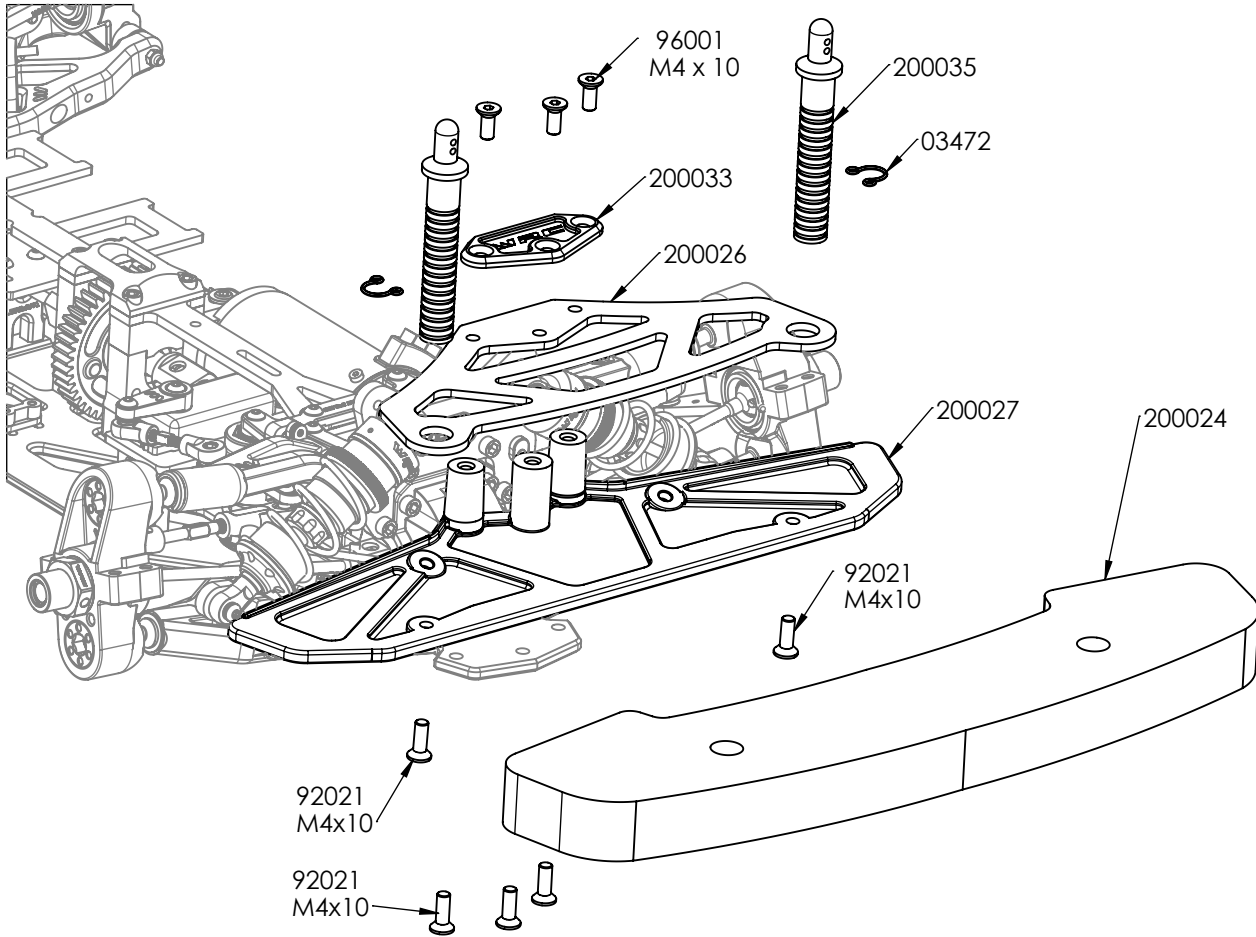

Batteries

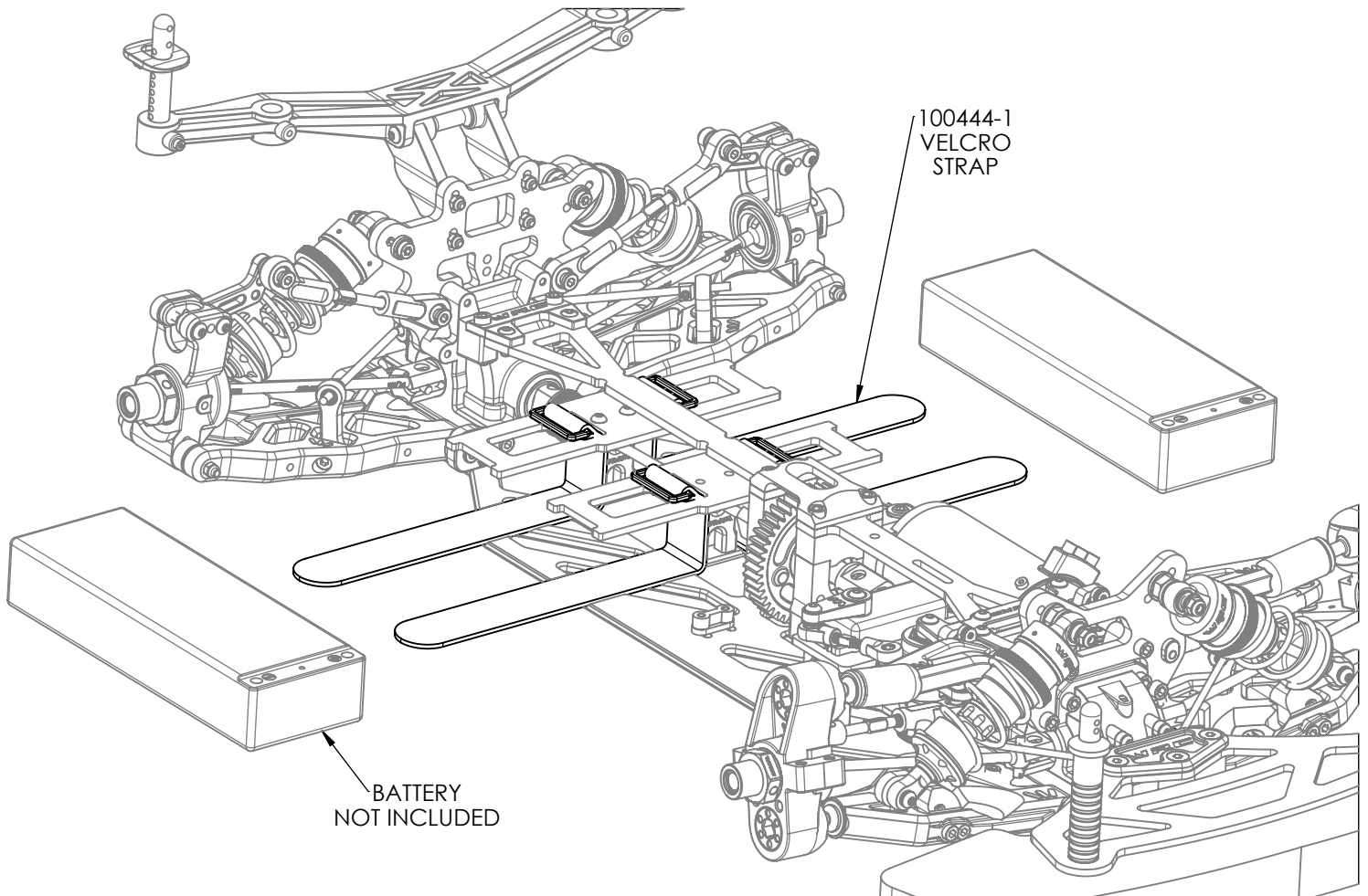

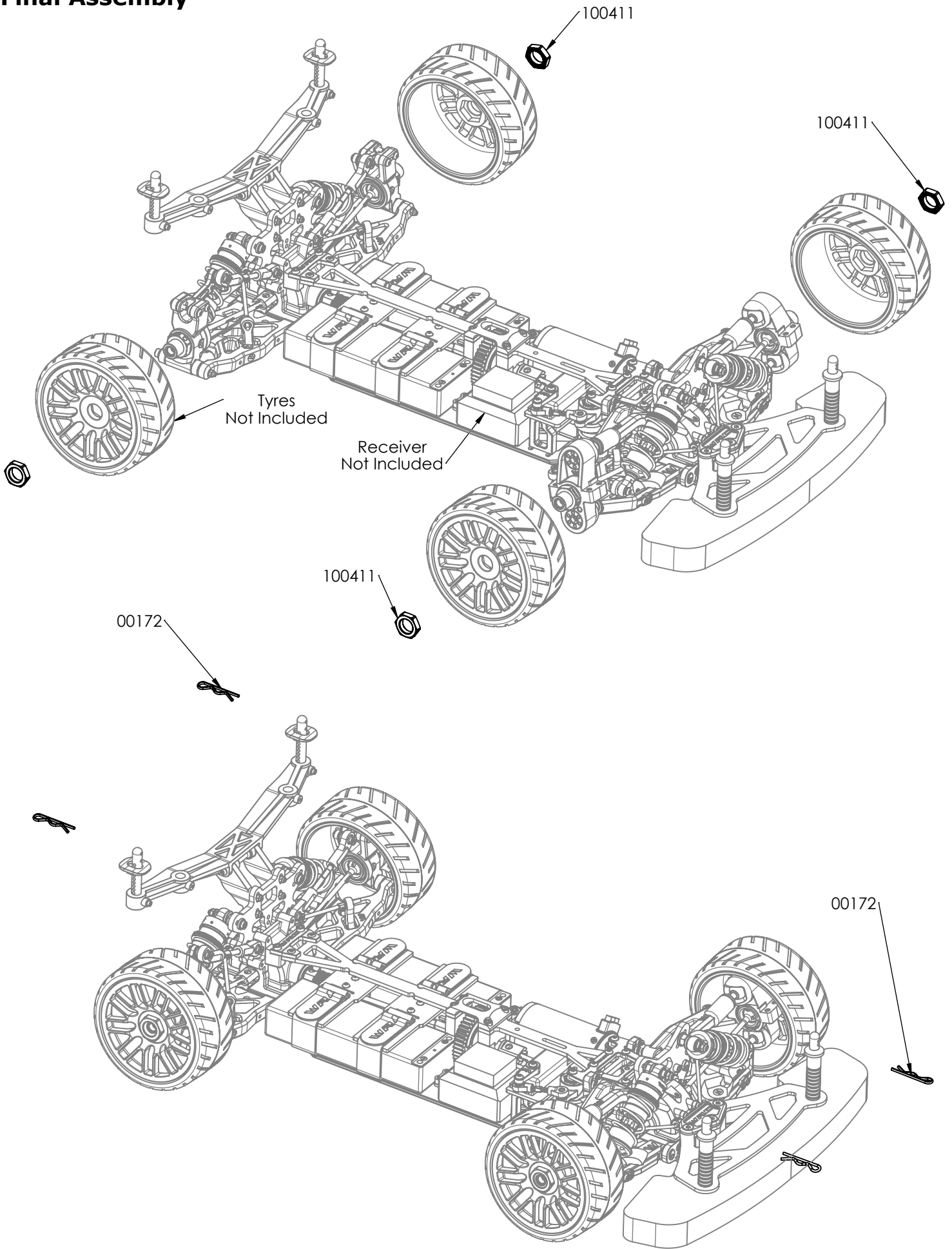

Driver:

Date:

Track:

Event:

Front Suspension:

Ride Height:

Camber:

Toe:

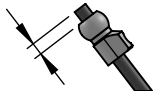
Anti-Roll Bar 

Size:

Gap:

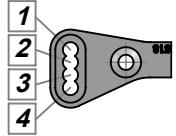
Ackerman 

1
2
3
4

Drive Shaft:

Chassie Brace:

Hex:

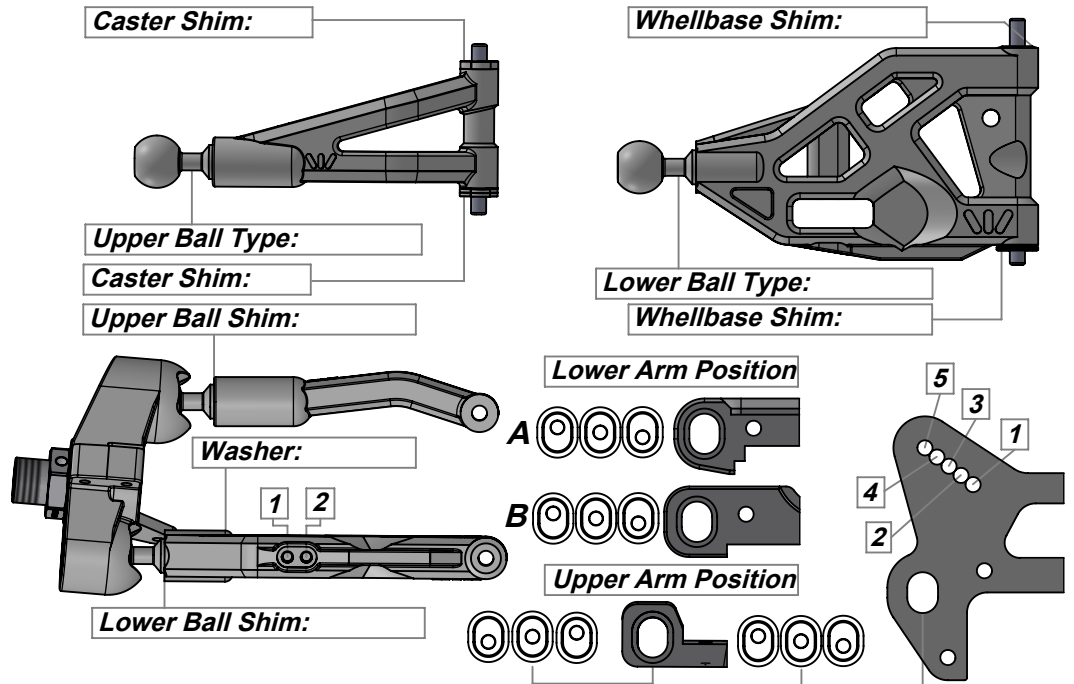

Rear Suspension:

Ride Height:

Camber:

Toe:

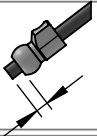
Anti-Roll Bar 

Size:

Gap:

Drive Shaft:

Chassie Brace:

Hex:

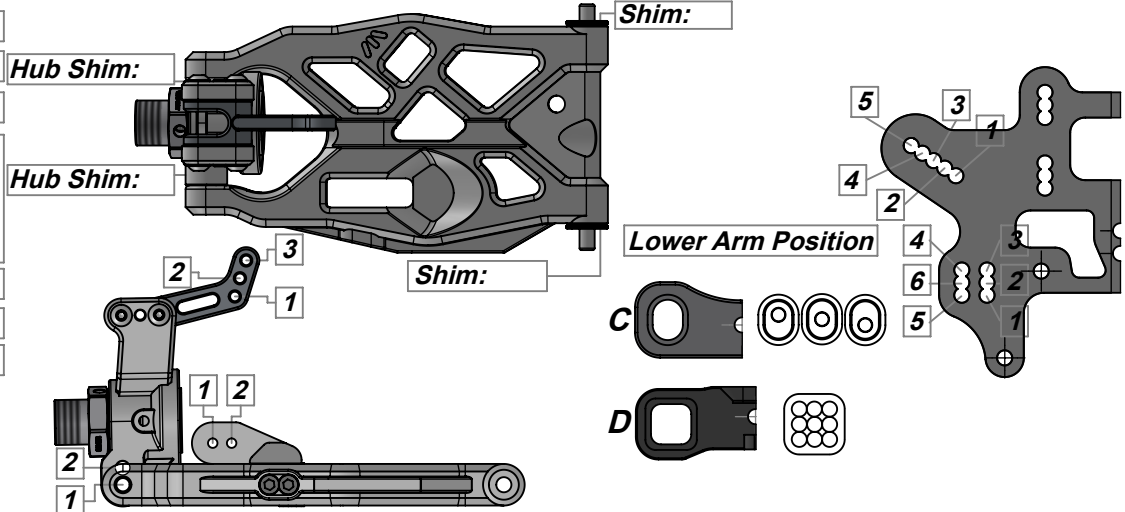

Shocks:

	Front	Rear
Piston:	<input type="text"/>	<input type="text"/>
Membrane:	<input type="text"/>	<input type="text"/>
Oil:	<input type="text"/>	<input type="text"/>
Spring:	<input type="text"/>	<input type="text"/>
Rebound:	<input type="text"/>	<input type="text"/>
Free Length:	<input type="text"/>	<input type="text"/>

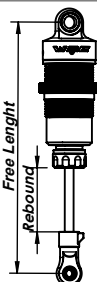

Electronics :

Radio:

Servo:

Epa: Throttle: % Brake: %

Expo: Throttle: % Brake: %

Esc:

Motor:

Battery:

Pinion and spur gear:

Pinion:

Spure gear:

Tracks:

Size : Type:

Traction:

Surface:

Differentials:

	Front	Rear
Case Mat.:	<input type="text"/>	<input type="text"/>
Oil:	<input type="text"/>	<input type="text"/>
Crown Gear:	<input type="text"/>	<input type="text"/>

Body, Wing:

Body:

Wing:

Manifold:

Wing Height:

Gap to tower:

Tires:

	Front	Rear
Brand:	<input type="text"/>	<input type="text"/>
Pattern:	<input type="text"/>	<input type="text"/>
Insert:	<input type="text"/>	<input type="text"/>
Whells:	<input type="text"/>	<input type="text"/>
Compound:	<input type="text"/>	<input type="text"/>

Note:

Tot. Car Weight:

WIRC
PROFESSIONAL RC CAR

WWW.WIRCRACING.COM