

STX.8

NEW GENERATION RC CAR

1/10 ELECTRIC
TOURING CAR 4WD



INSTRUCTION MANUAL

WIRC
PROFESSIONAL RC CAR

WWW.WIRCACING.COM

INTRODUCTION

STX is a new generation high quality 1/10 scale touring car. STX is supplied in a box equipped with Instruction Manual. Its use is intended for more than 16 years old persons with experience on rc model car field. Children and all the persons without this requirement MUST have direct supervision of a knowledgeable adult responsible.

SAFETY PRECAUTIONS

Instruction Manual MUST be read and fully understood before to start building and operating functions.
Always keep Instruction Manual in safety place, ready to be consulted for any reference you need.
Use only original WIRC spare parts.

GENERAL INFORMATION

Assemble the kit only away from the reach of children.
Follow the building and operating instructions using the utmost care.
Don't put any part of your body inside rotating and moving elements as this may cause damage or serious injury.
Check and clean the model before putting it away.
Don't use your model car in public places or in roads and areas where it could generate conflict with person or vehicular traffic.
The model car is controlled by radio: you MUST put great care to avoid loss of radio control always keeping a safety margin all around your model in order to prevent any collision.
Operating frequency: check and be sure it is clear and not shared with anybody at same time; it could cause loss of control of the RC model.
Always turn on your transmitter before you turn on the receiver in the car and always turn off the receiver before you turn off your transmitter.
Keep the wheels of the model off the ground when checking the operation of the radio equipment.
Disconnect the battery pack before storing your model.

WARRANTY

WIRC guarantees this model kit to be free from defects in both material and workmanship within 30 days of purchase.
The total monetary value under warranty will in no case exceed the cost of the original kit purchased.
This warranty doesn't cover any components damaged by use or modification or as result of wear.
Part or parts missing from this kit must be reported within 30 days of purchase.
No part or parts will be sent under warranty without proof of purchase.
If you find a defective or missing part, contact the local distributor.
Customer service and support will be provided through local hobby store.
No warranties are expressed or implied that cover damage caused by what is considered normal use or cover or imply how long any model cars' components or electric components will last before requiring replacement.
Due to the high performance level of this model car you will need to periodically maintain and replace consumable components; any and all warranty coverage will not cover replacement of any part or component damaged by neglect, abuse or improper or unreasonable use.
This includes but is not limited to damage from crashing, excessive moisture, improper use or no maintenance or user modifications which compromise the integrity of components.
Warranty will not cover components that are considered consumable on RC model car.
WIRC doesn't pay nor refund on any component sent from WIRC or its distributor for warranty.
WIRC reserves the right to make final determination of the warranty status of any component or part
Use only original WIRC spare part:

CUSTOMER SUPPORT

Please don't hesitate to contact WIRC support at info@wircracing.com for any problem or question. Also kindly visit our website www.wircracing.com to find last updates, set-up information, option parts and other information.

World racing car s.r.l.

Via A. Volta, 2 bis
36040 Brendola (VI)
ITALY

Phone: 0039 0444 1792263
E-mail: info@wircracing.com
Website: www.wircracing.com

STX

TECHNICAL INFORMATION

- TRANSMISSION: 4 DRIVE WHEELS
- BODY: TOURING MODEL (NOT INCLUDED)
- ADJUSTABLE FRONT TOE, CAMBER AND CASTER
- ADJUSTABLE REAR TOE AND CAMBER
- BUMPER /FRONT BACKSTOP
- CARBON CHASSIS
- FULL BALL BEARING
- DIFFERENTIAL GEAR

TECHNICAL DATA

- LENGHT 373 MM.
- WIDTH 187 MM.
- ADJUSTABLE WHEEL BASE MIN. 250 MM. - MAX 256 MM.
- WEIGHT CHASSIS..... 515 GR.

ADDITIONAL ITEMS NEEDED FOR COMPLETION (REQUIRED BUT NOT INCLUDED IN THE KIT)



ELECTRIC MOTOR
PINION GEAR



TRANSMITTER



RECEIVER



LOW PROFILE STEERING SERVO



BATTERIES
FOR TRANSMITTER



WHEEL - TYRES - INSERTS



LIPO BATTERY



SPEED CONTROLLER



LEXAN BODY +
DECALS
INCLUDED

TOOLS REQUIRED

THESE TOOLS ARE NOT INCLUDED IN THE KIT BUT ARE REQUIRED FOR PROPER ASSEMBLY



ALLENS:
1.5 mm
2 mm
3 mm



SOCKET
5mm
7mm



SIDE CUTTERS



COMBINATION PLIERS



SCISSORS



TOOL FOR
TURNBUCKLES/NUTS



GREASE



OILS:
BEARING OIL
SILICONE OIL

NOTICE:

THE FOLLOWING ITEMS ARE NEEDED FOR COMPLETION OF THE STX; THEY ARE NOT INCLUDED IN THIS KIT (UNLESS NOTED) AND SHOULD BE OBTAINED FROM YOUR LOCAL HOBBY SHOP. BE SURE TO READ THE INSTRUCTION COMPLETELY PRIOR TO ASSEMBLY

Front Bulkheads

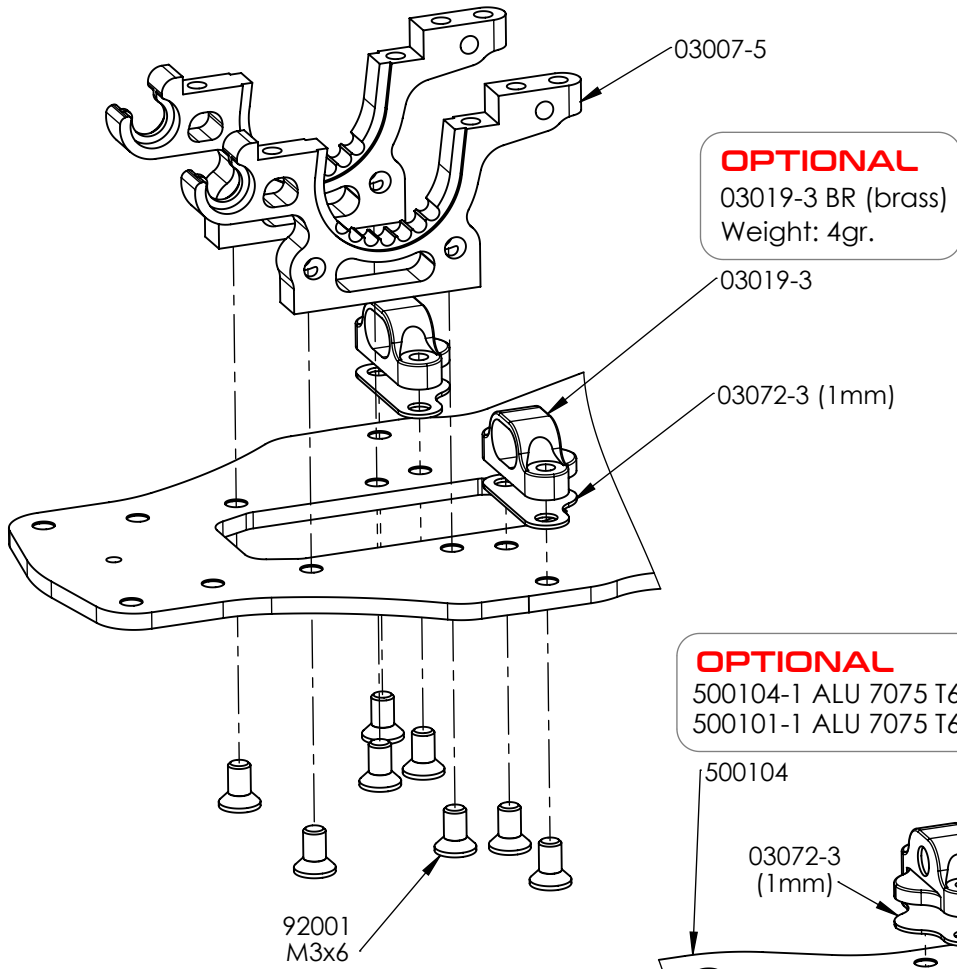

Rear Bulkheads

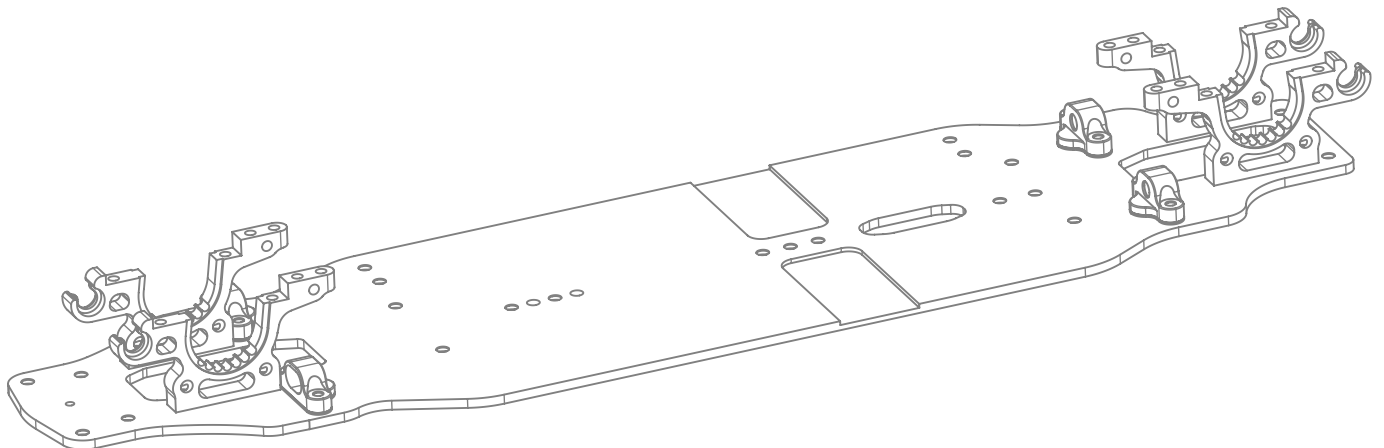
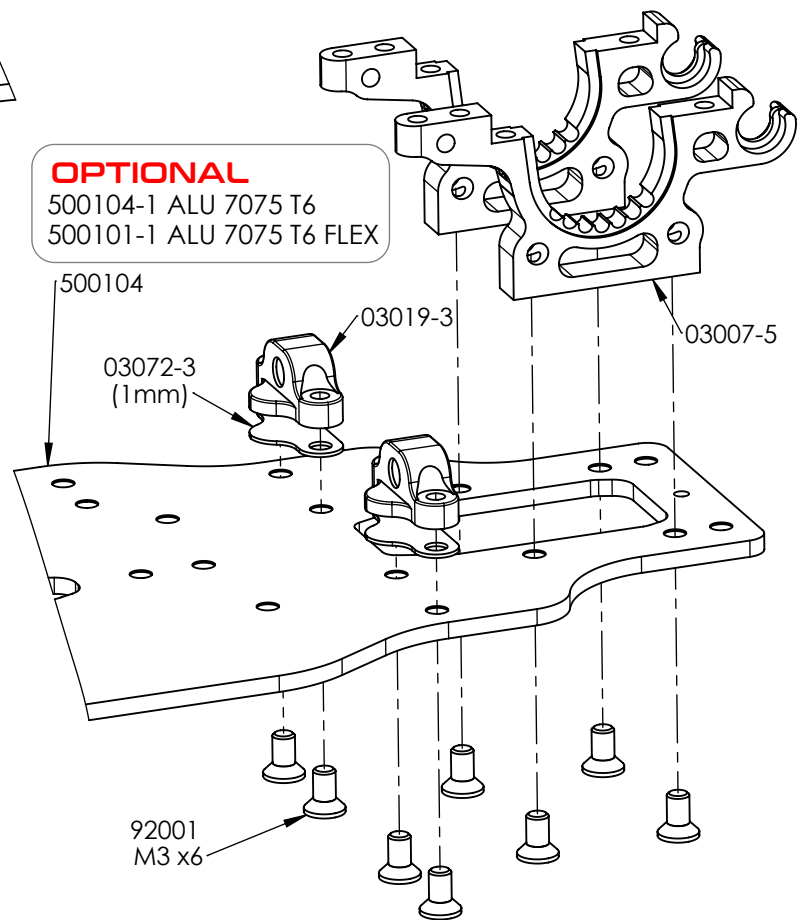

Rear Differential Gear

FOLLOW CLOSELY THE INSTRUCTIONS, THIS DIFF GEAR HAS TO BE MOUNTED CORRECTLY TO WORK WELL

1

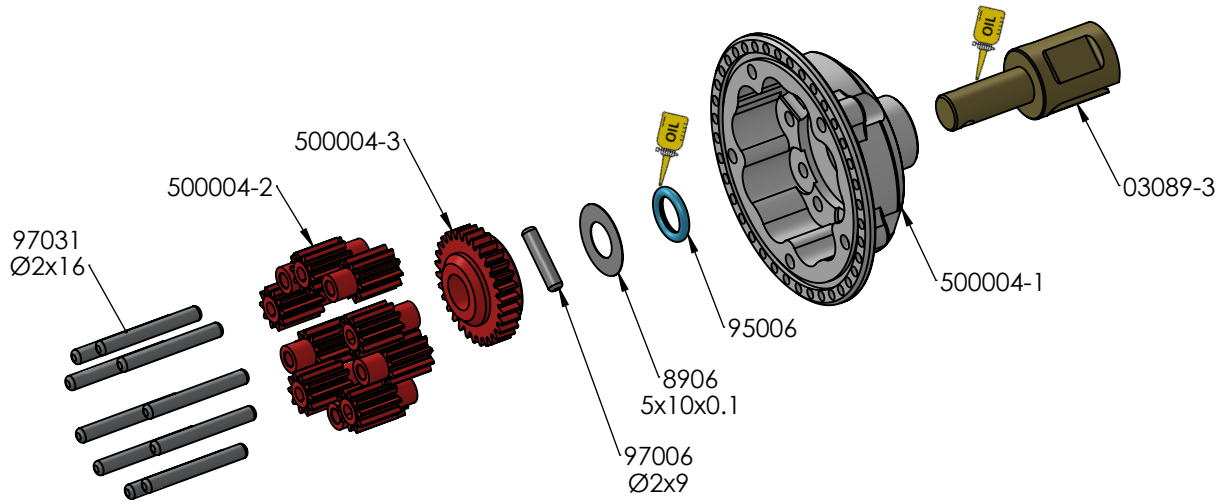

2

SILICONE OIL 1000 Q.ty 1g

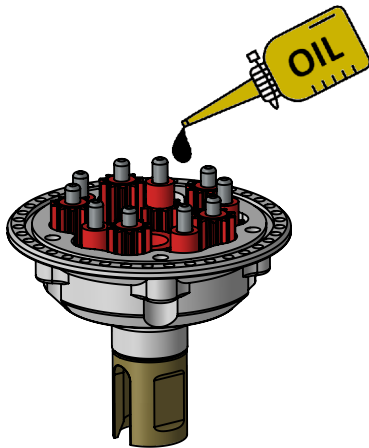

3

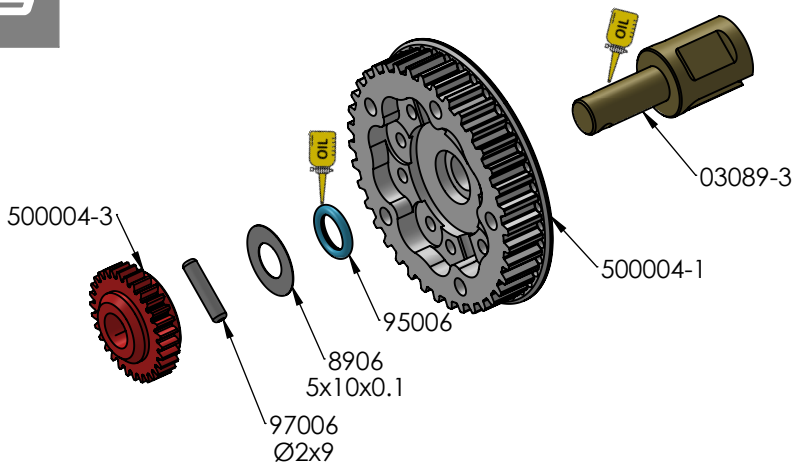

4

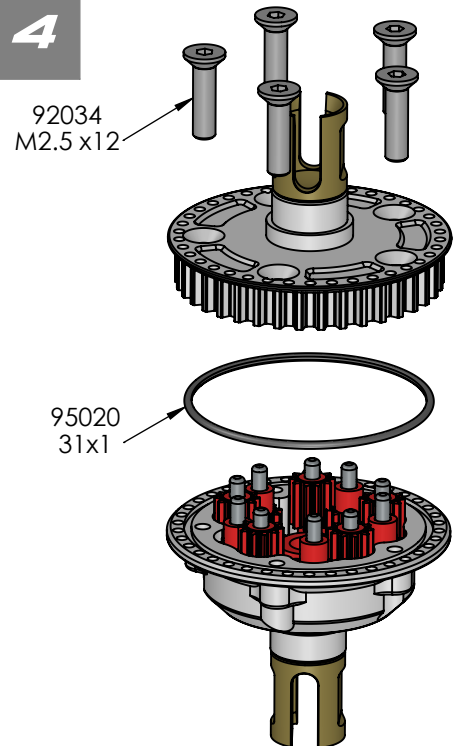

If the gears are aligned the 2 sides of the Diff should close easily.

DON'T FORCE IT TO CLOSE

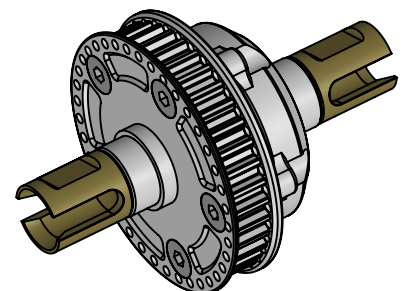

4

Central Transmission

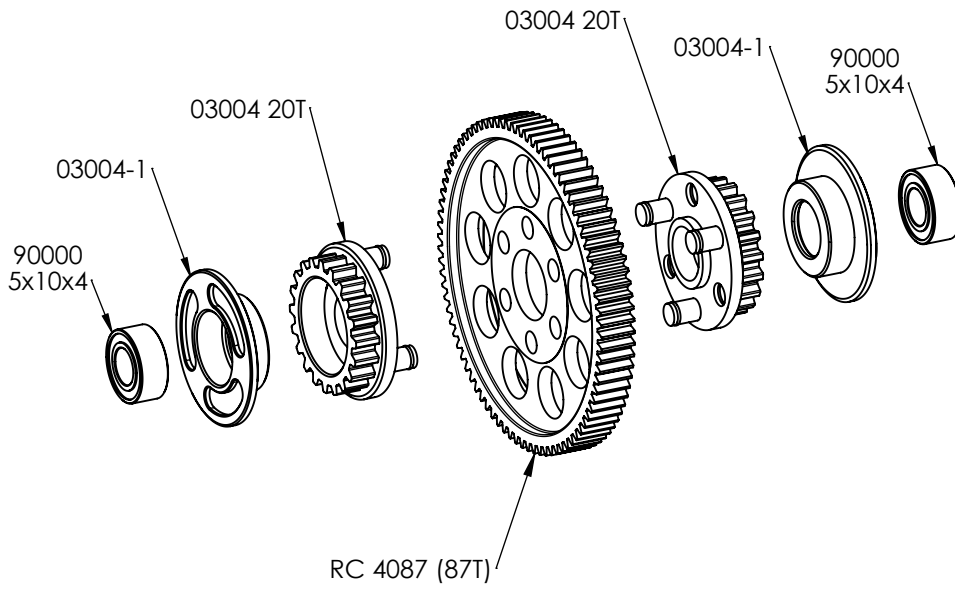

SPUR GEAR P48

RC4078	78 T
RC4084	84 T
RC4087	87 T

SPUR GEAR P64

RC6092	92 T
RC6096	96 T
RC60100	100 T
RC60104	104 T
RC60106	106 T
RC60108	108 T
RC60110	110 T
RC60112	112 T
RC60114	114 T
RC60116	116 T
RC60118	118 T

Solid Front Axel

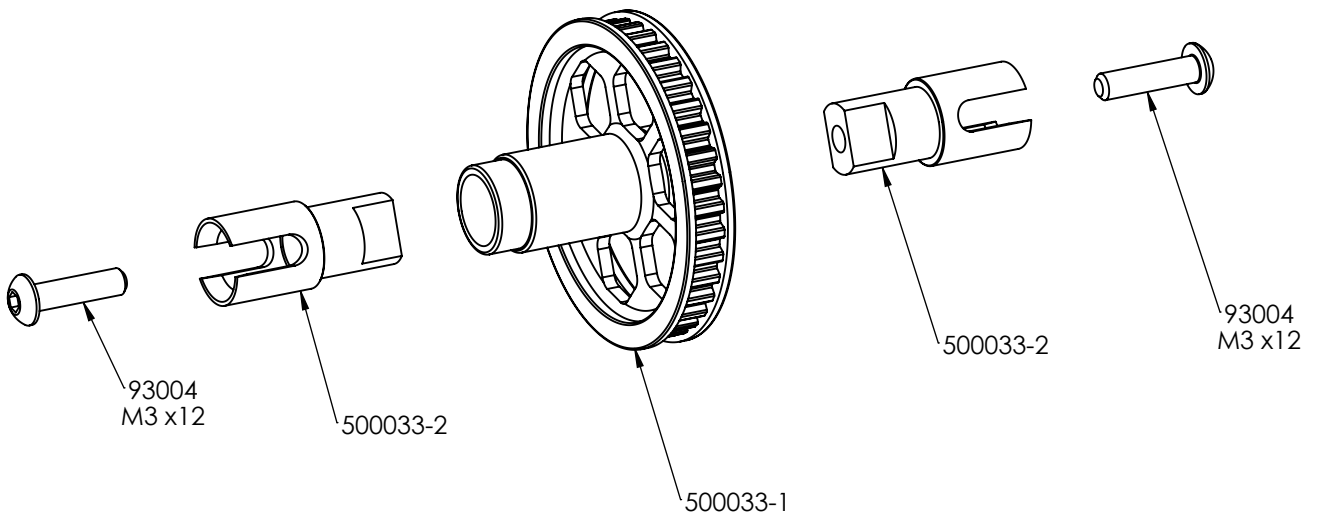

BAG 4 Transmission

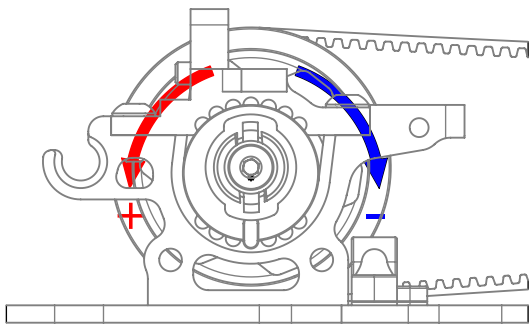
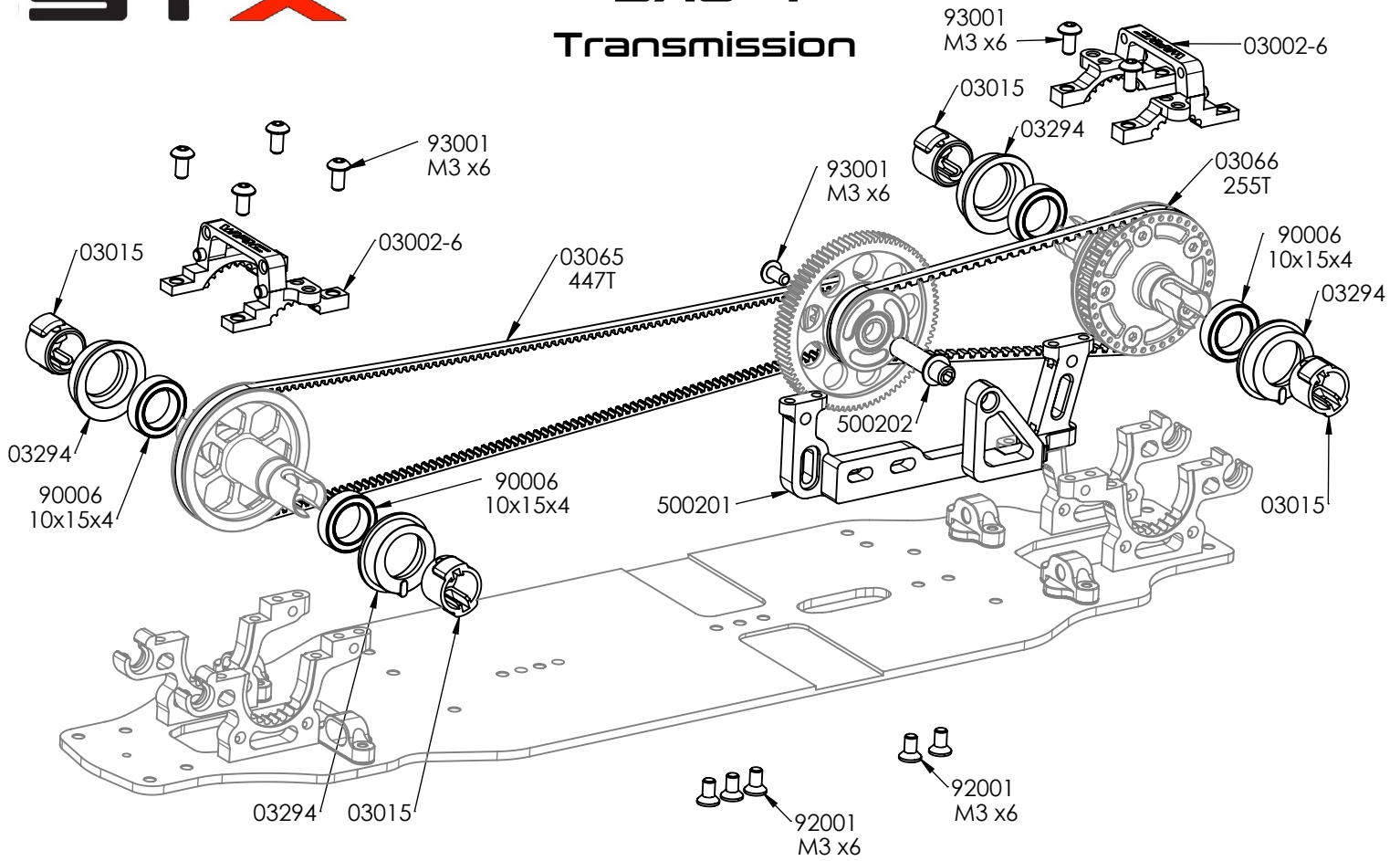

FRONT BELT ADJUSTMENT

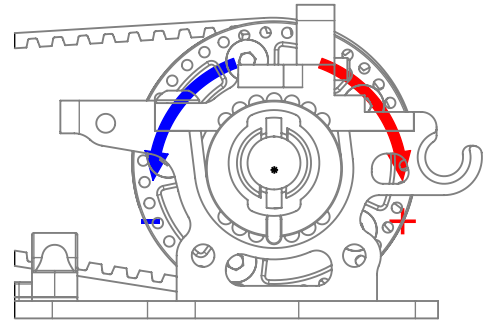

REAR BELT ADJUSTMENT

Belt Tensioner

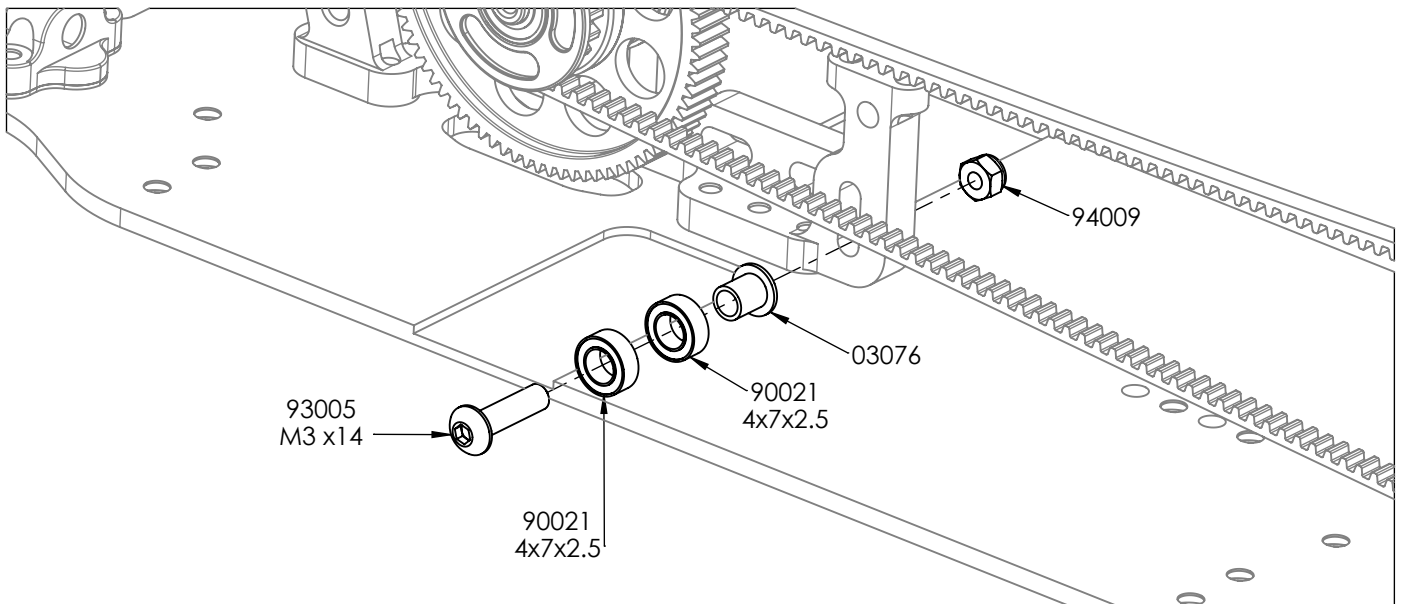

Front Lower Arms

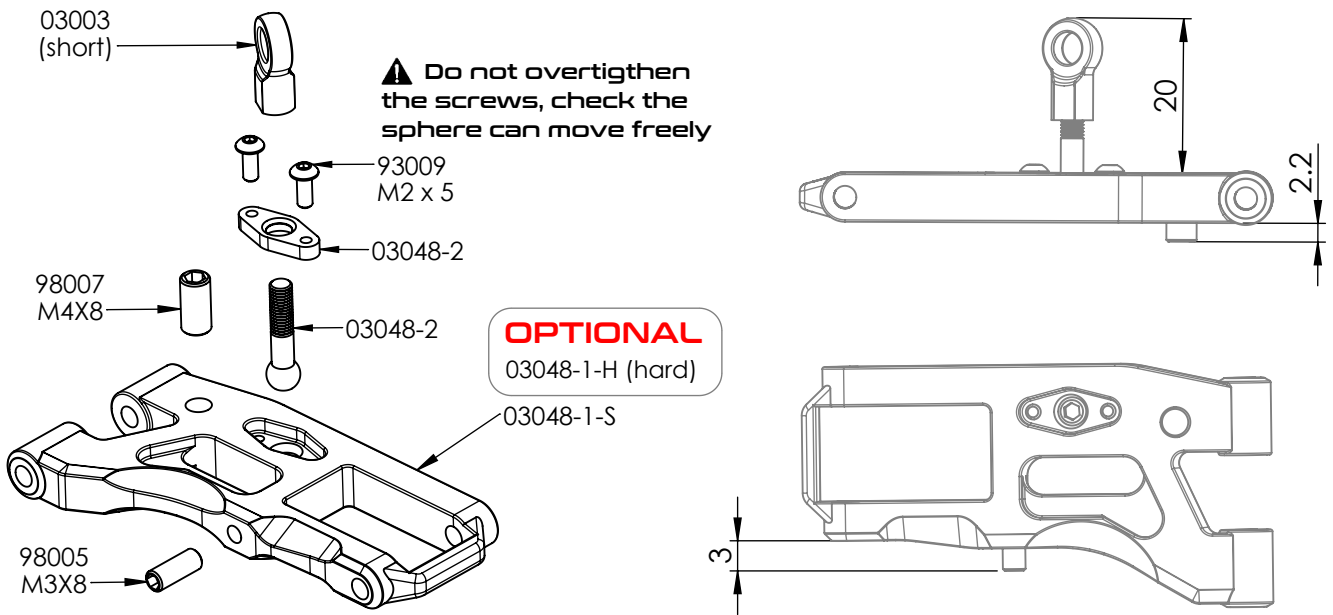

LEFT SIDE SHOWN ABOVE

Rear Lower Arms

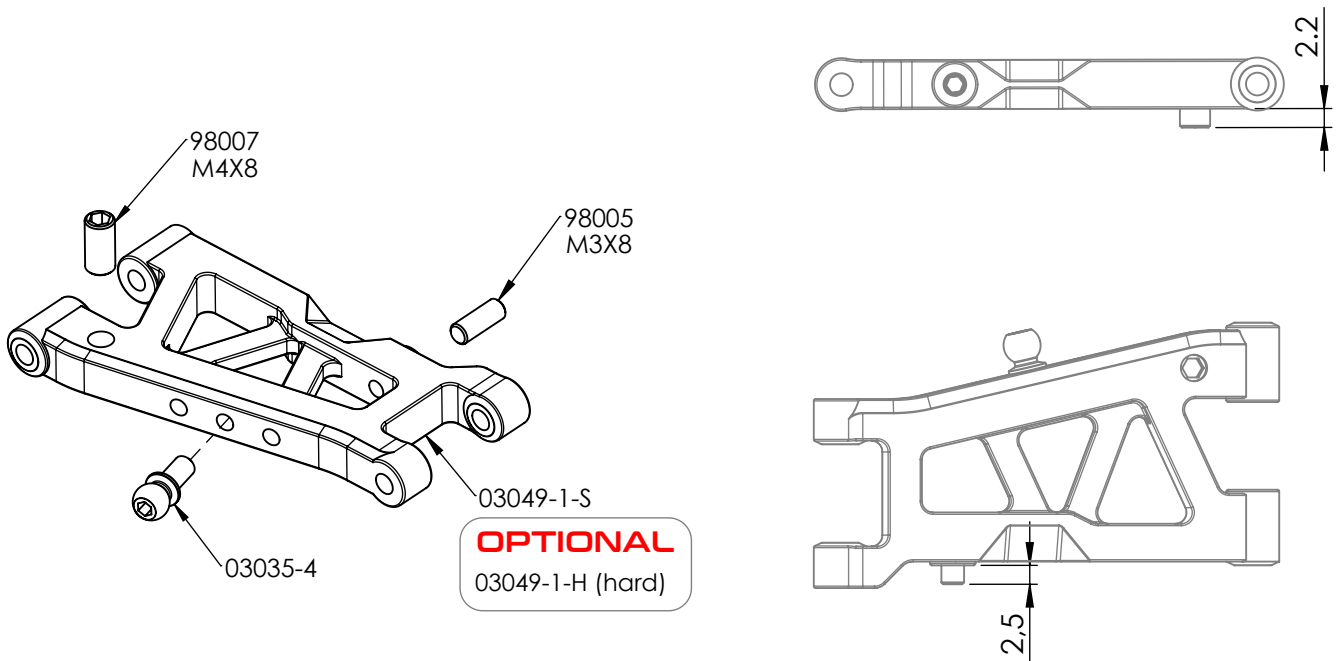

LEFT SIDE SHOWN ABOVE

Front Arm Angles Diagram

STX		FR MOUNT					
FRONT		43,5	44,5	45	46	47	47,5
FF MOUNT		0°	0,5°	1°	1,5°	2°	3°
		-0,5°	0°	0,5°	1°	1,5°	2°
		-1°	-0,5°	0°	0,5°	1°	1,5°
		-1,5°	-1°	-0,5°	0°	0,5°	1°
		-2°	-1,5°	-1°	-0,5°	0°	0,5°
		-3°	-2°	-1,5°	-1°	-0,5°	0°

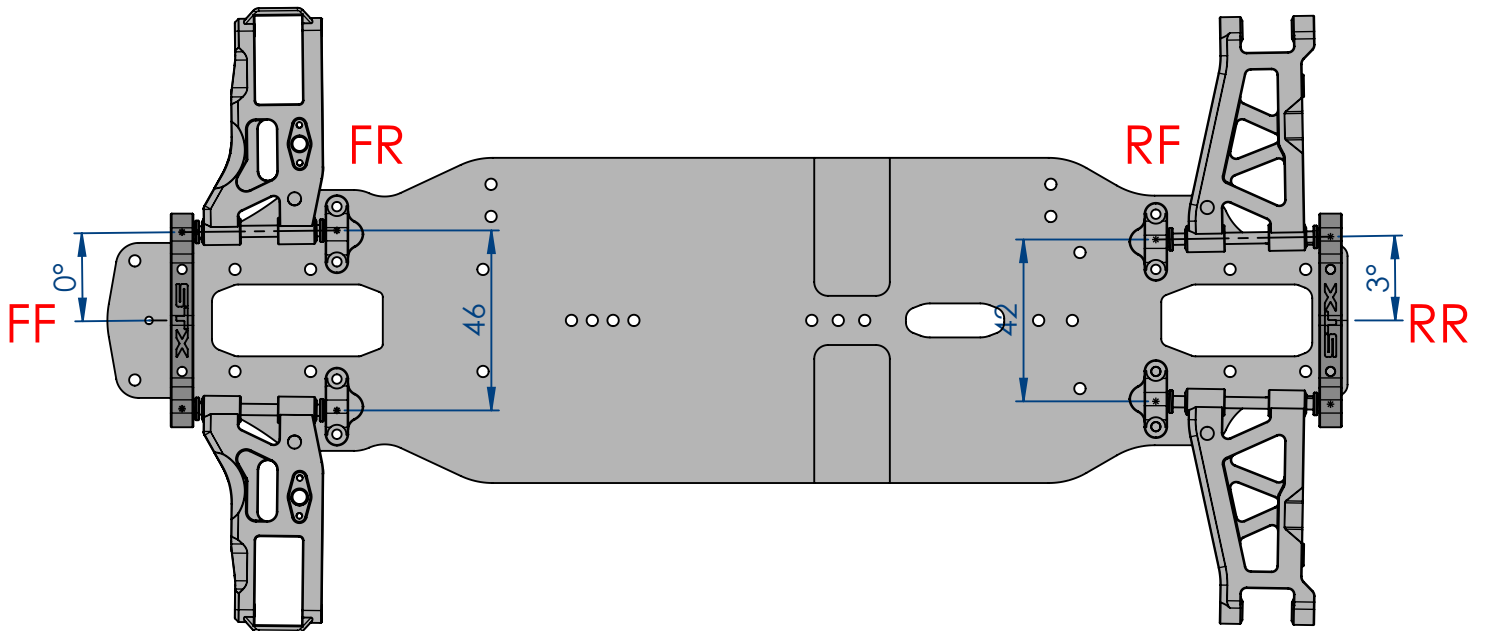
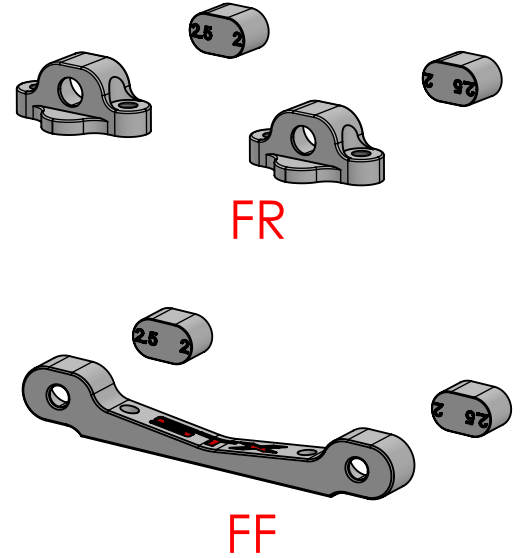

Rear Arm Angles Diagram

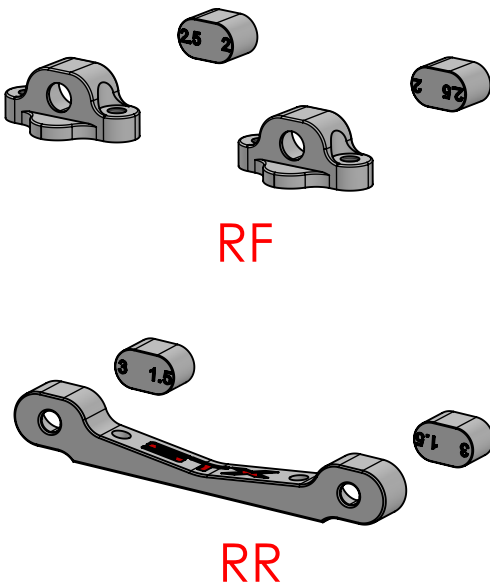

STX		RF MOUNT					
REAR		39,5	40,5	41	42	43	43,5
RR MOUNT		2,5°	2°	1,5°	1°	0,5°	0°
		3°	2,5°	2°	1,5°	1°	0,5°
		3,5°	3°	2,5°	2°	1,5°	1°
		4°	3,5°	3°	2,5°	2°	1,5°
		4,5	4°	3,5°	3°	2,5°	2°
		5°	4,5	4°	3,5°	3°	2,5°

Rear Lower Arms Mounting

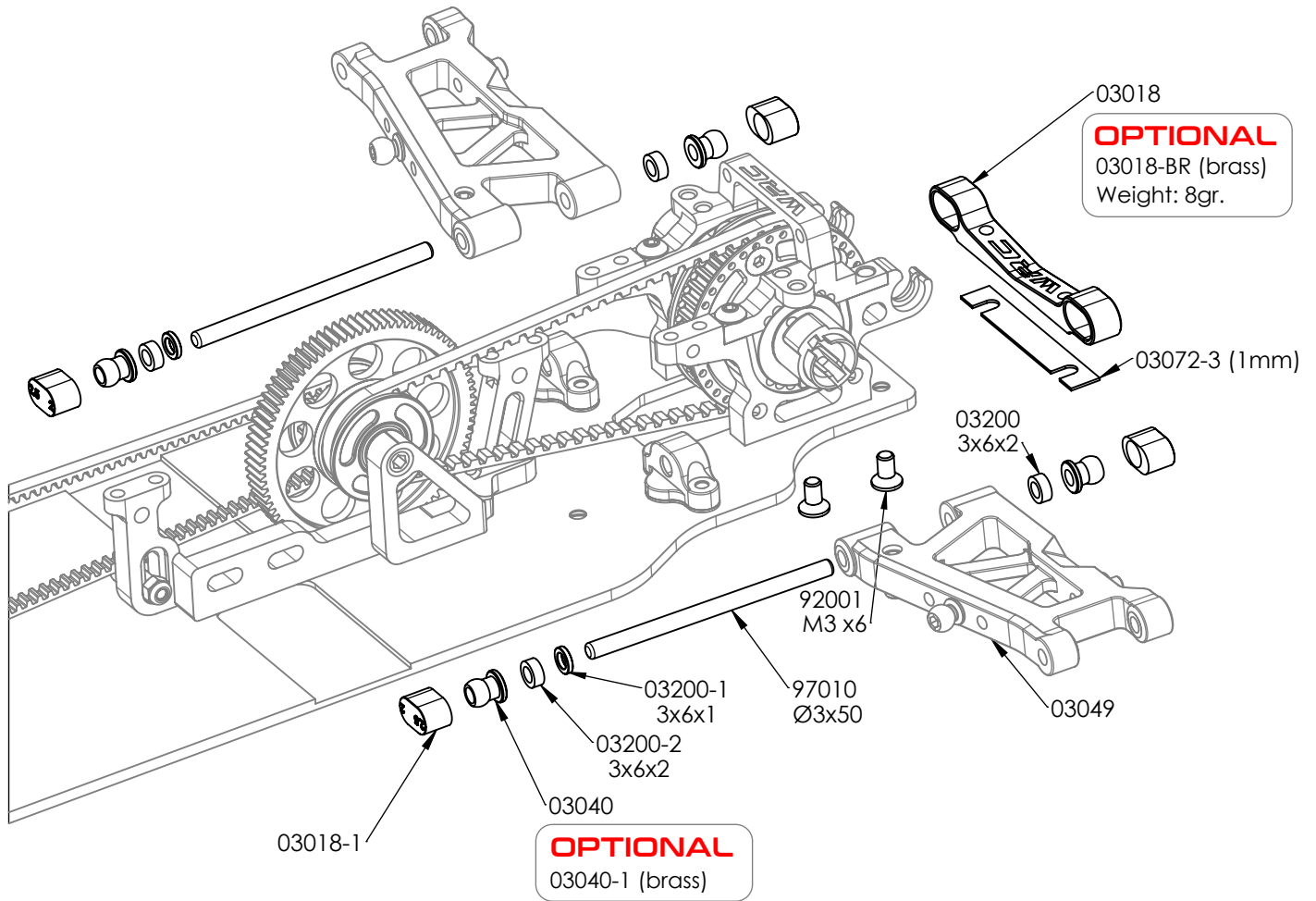

Front Lower Arms Mounting

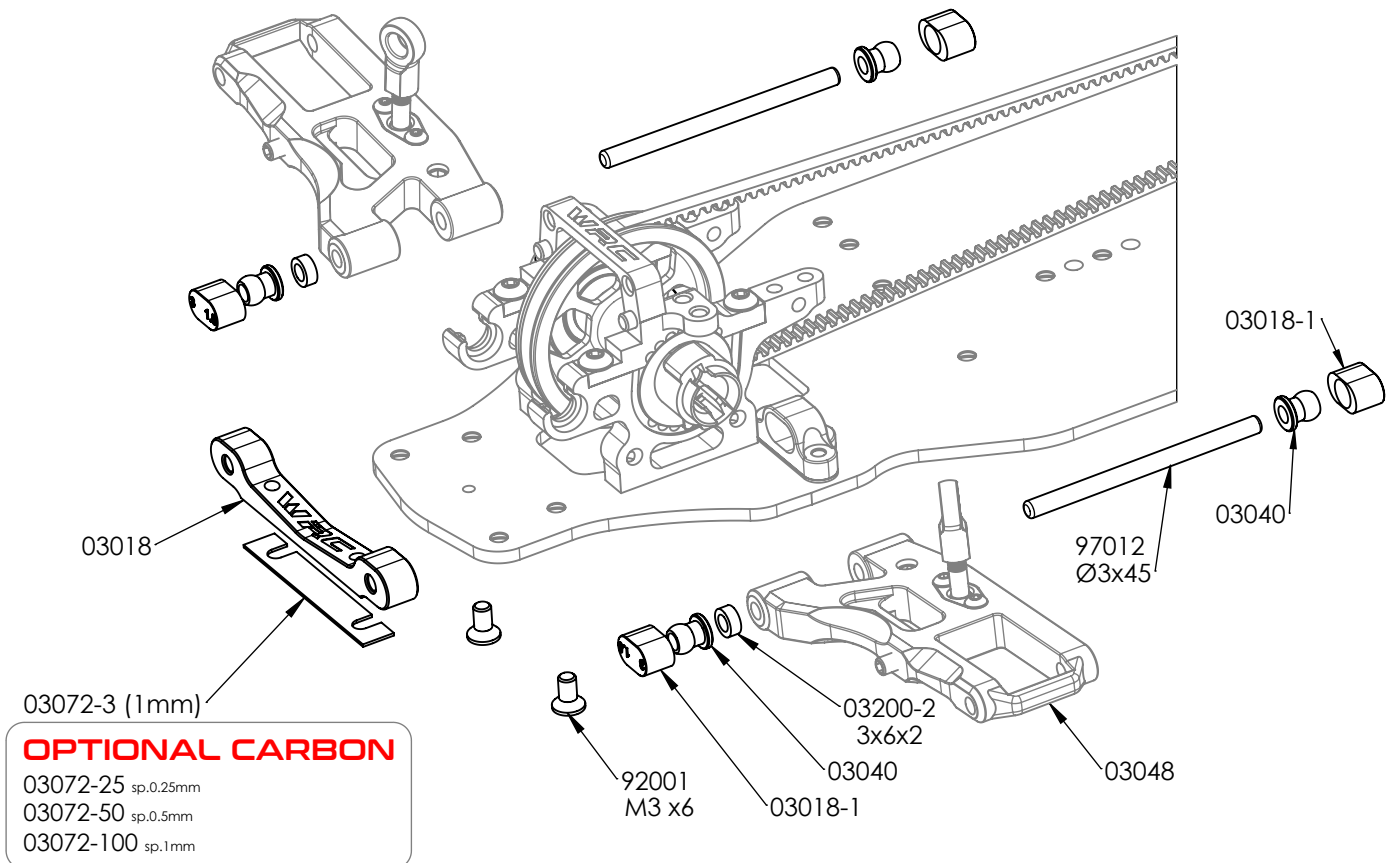

Left & Right Front Hub

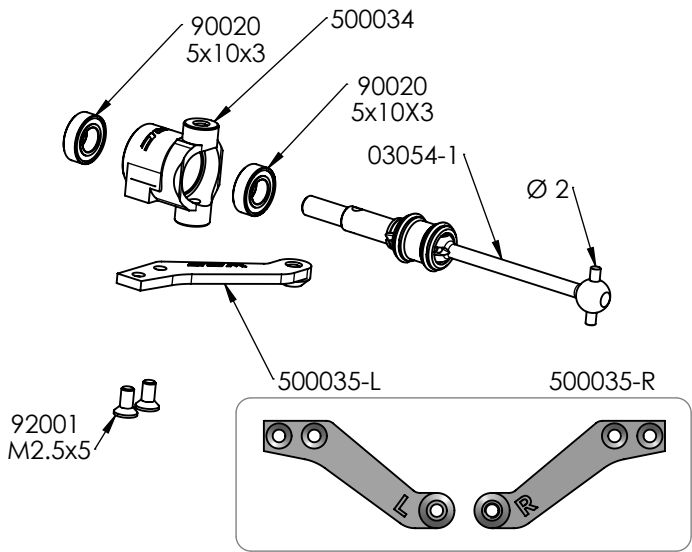

OPTIONAL
03082-5.5
03082-6.0

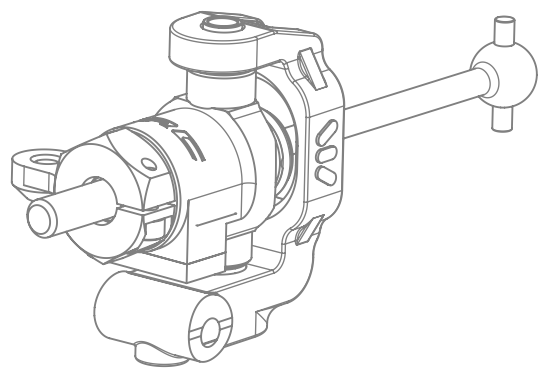
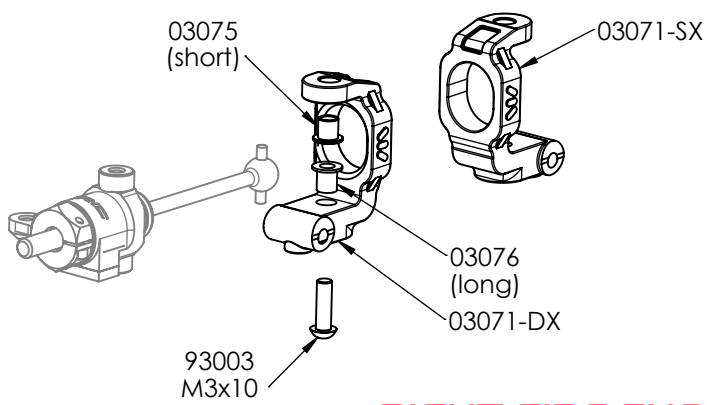
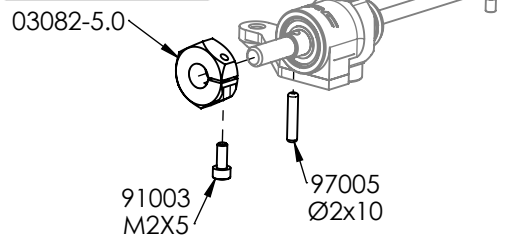

RIGHT SIDE SHOWN ABOVE

Rear Hub

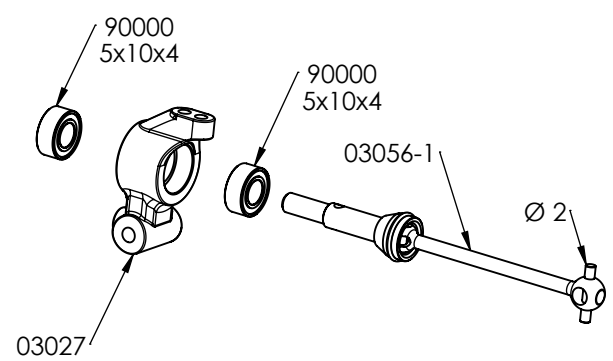

OPTIONAL
500036
ALU 7075 T6

OPTIONAL
03082-5.5
03082-6.0

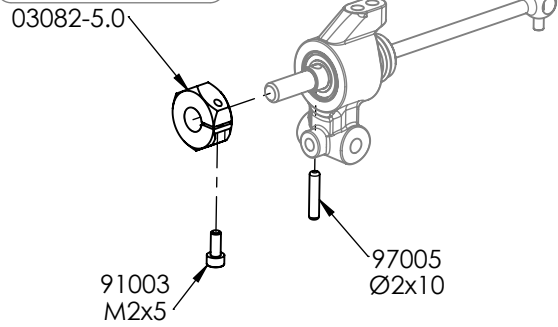

Front Upper Arms

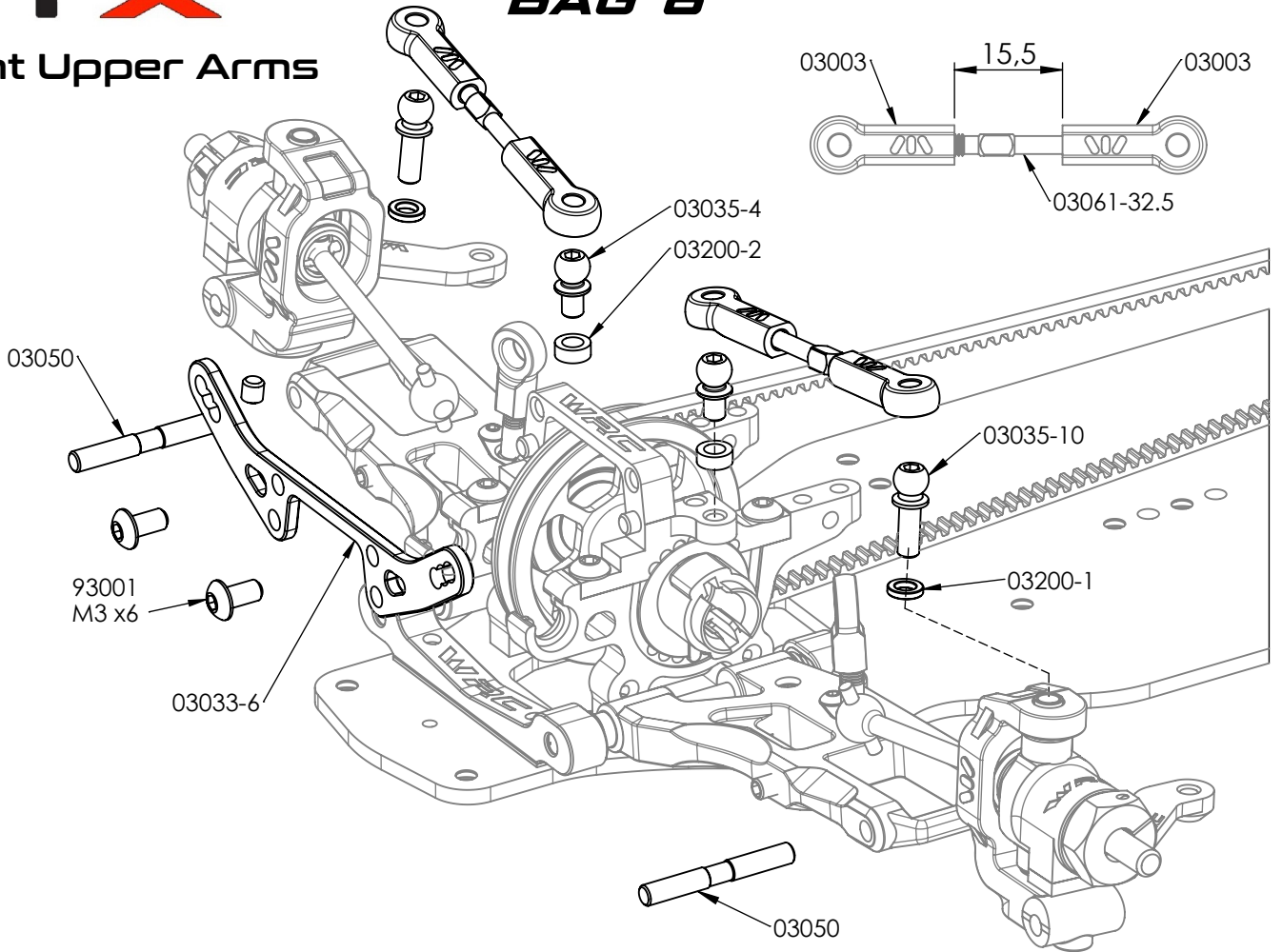

Rear Upper Arms

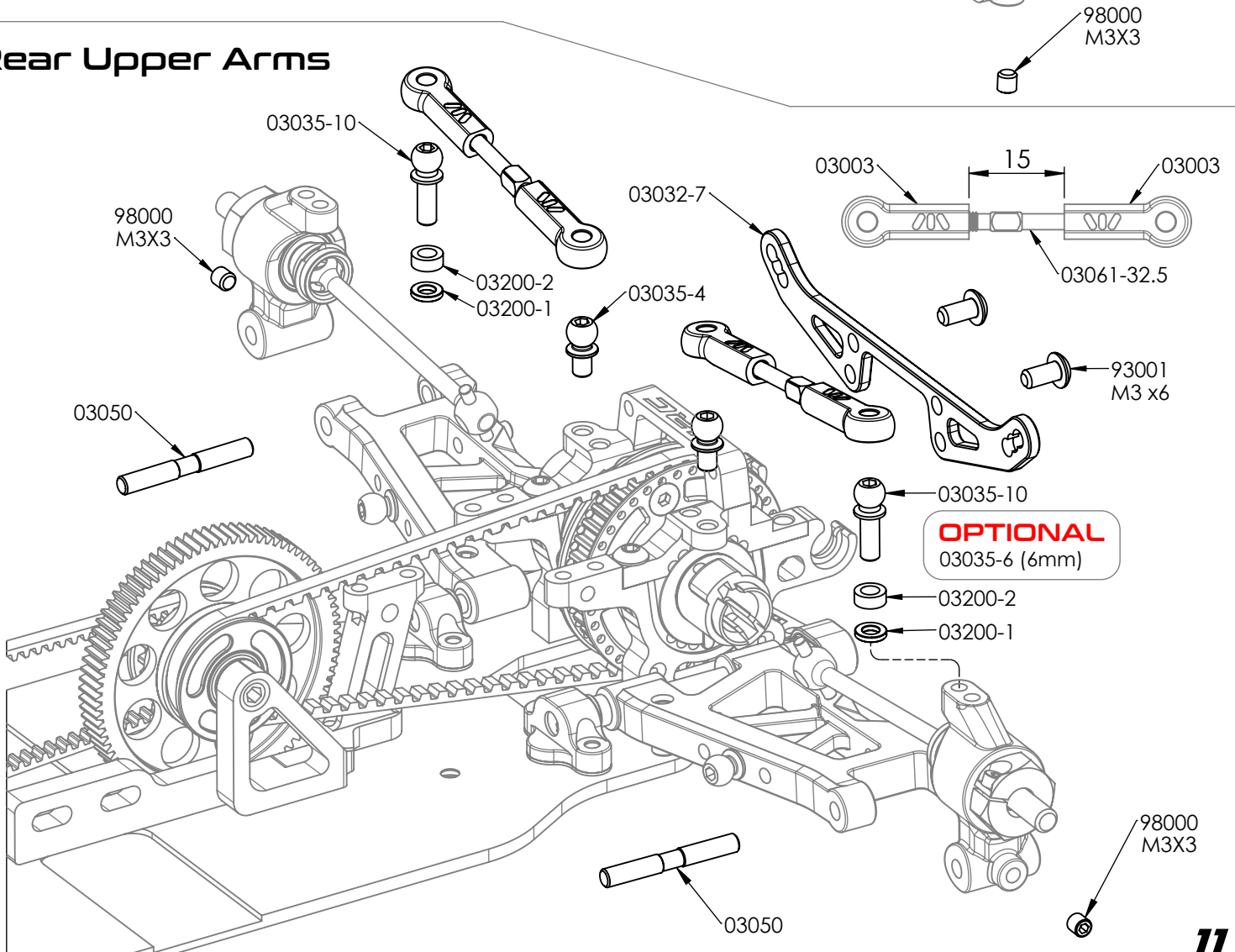

Servo

Adjust the distance from the servo lever to the ball as needed using the alu shims.

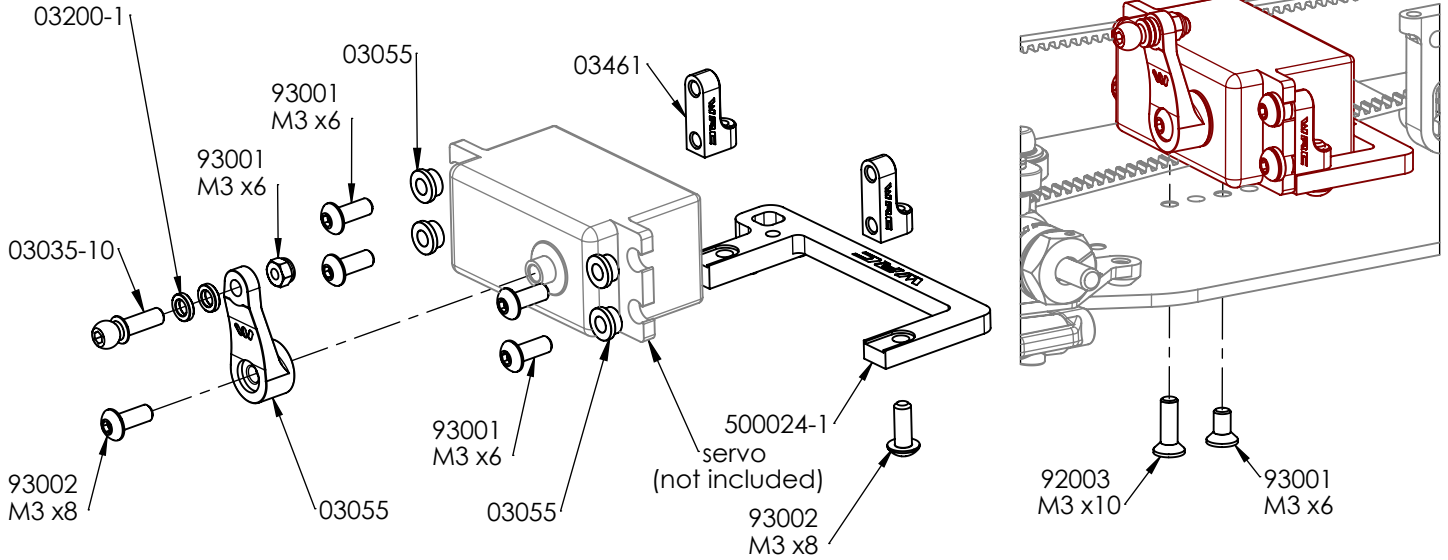

Steering levers

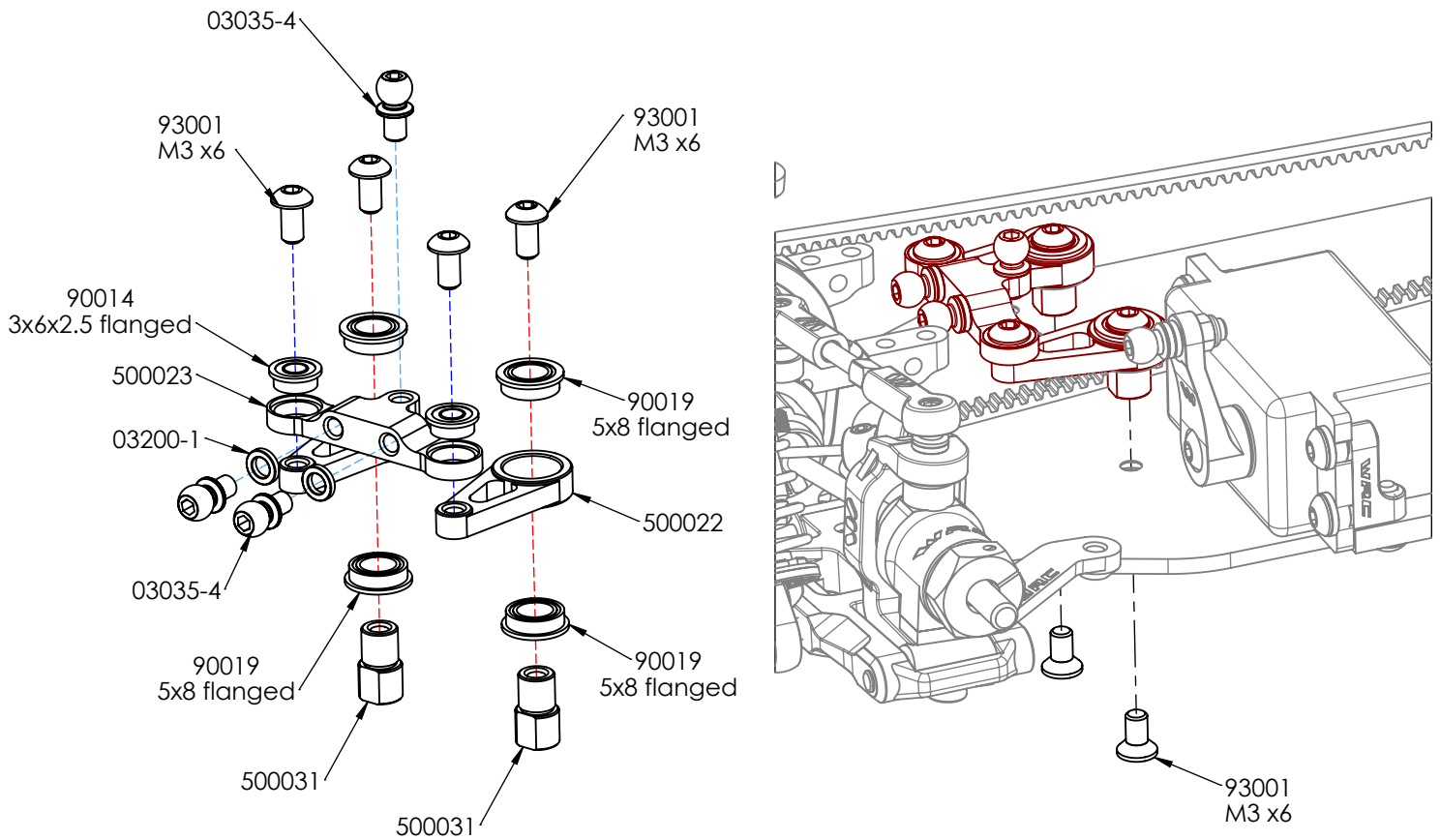

Steering Arms

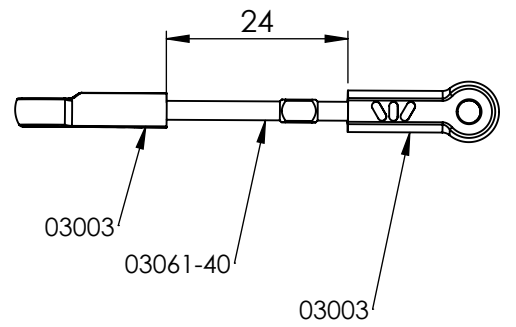
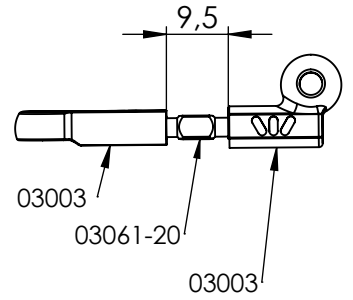
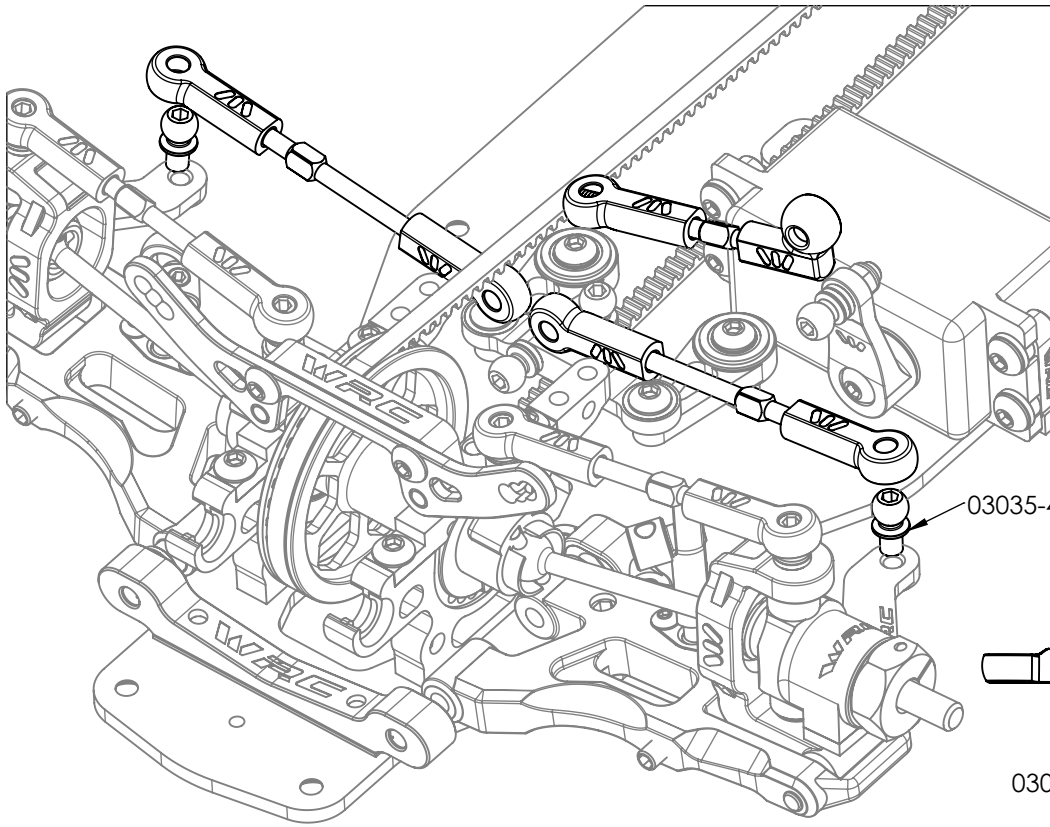

Upperdeck

OPTIONAL

500406-3

One piece upperdeck

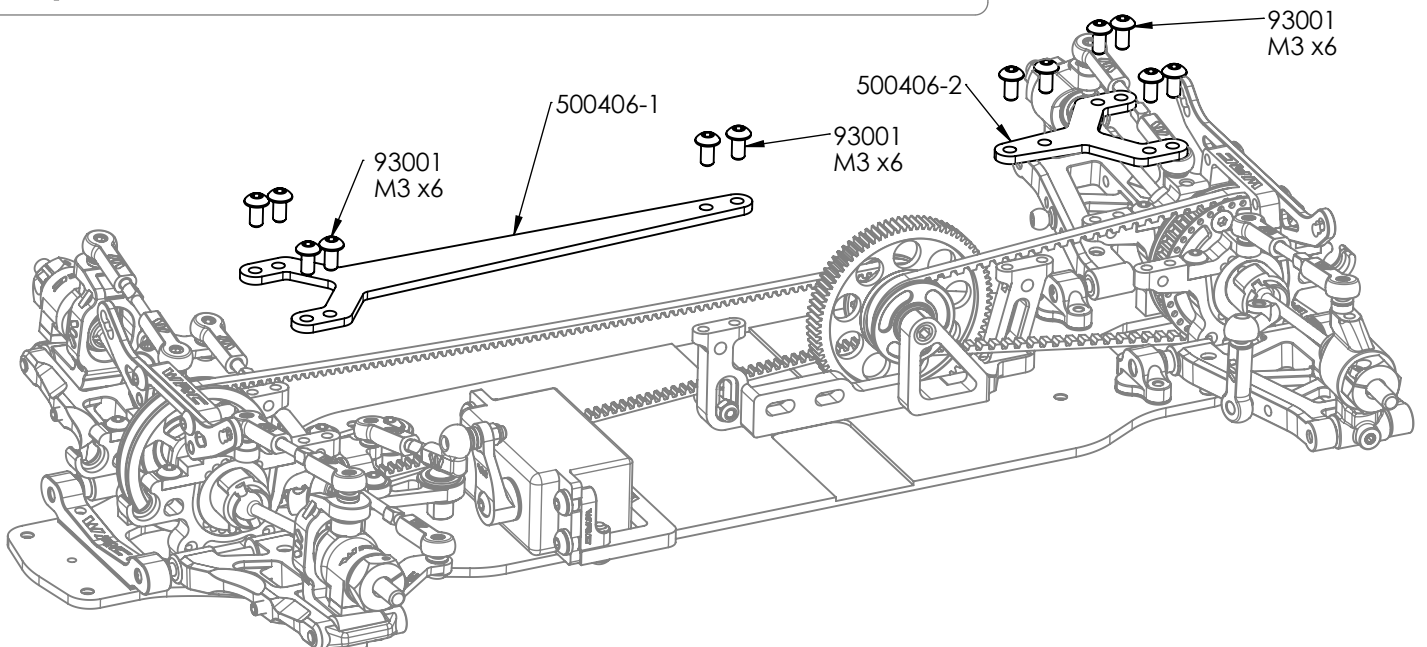
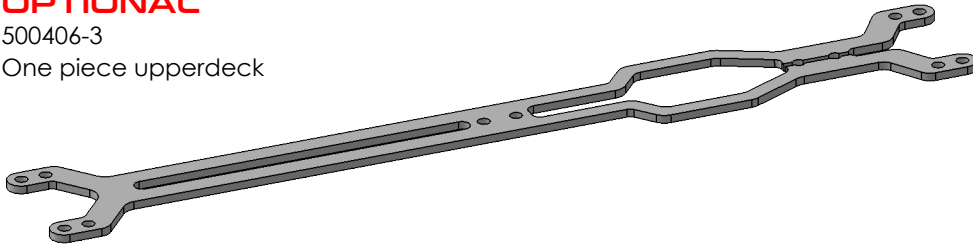

Front Anti Roll Bar

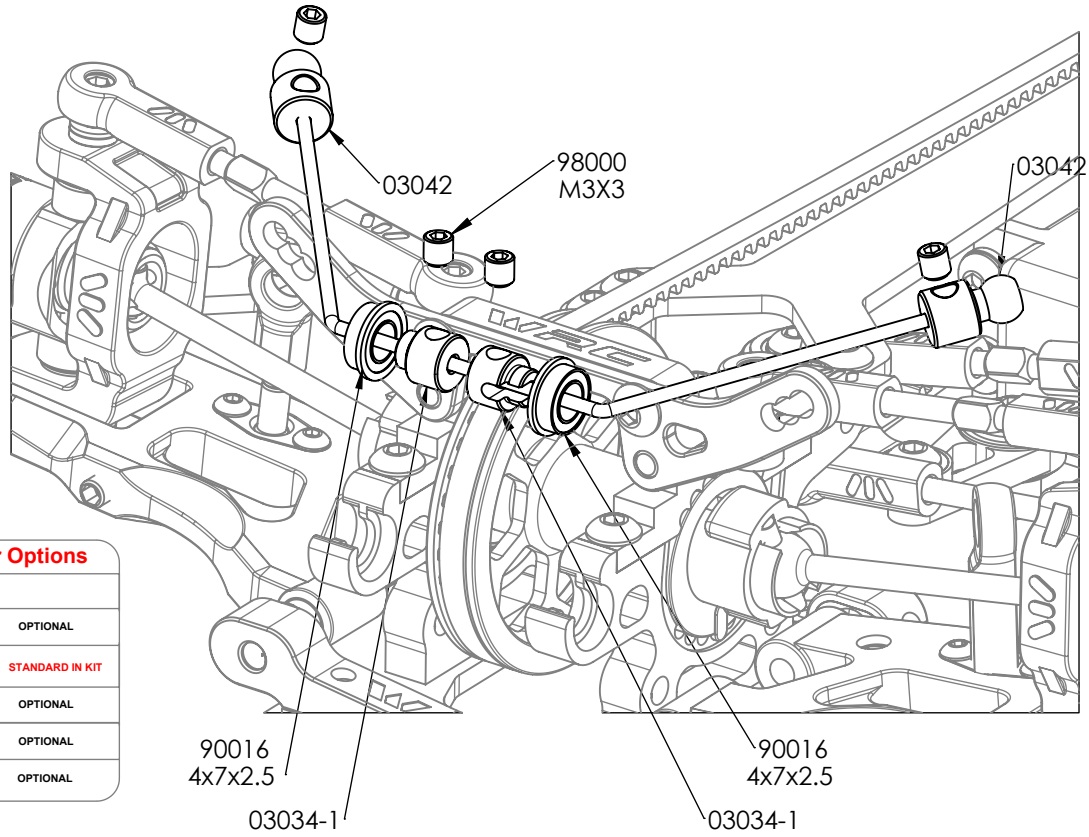

Front Anti Roll Bar Options

COD	Ø	
03031-2	Ø 1.2	OPTIONAL
03031-3	Ø 1.3	STANDARD IN KIT
03031-4	Ø 1.4	OPTIONAL
03031-5	Ø 1.5	OPTIONAL
03031-6	Ø 1.6	OPTIONAL

Rear Anti Roll Bar

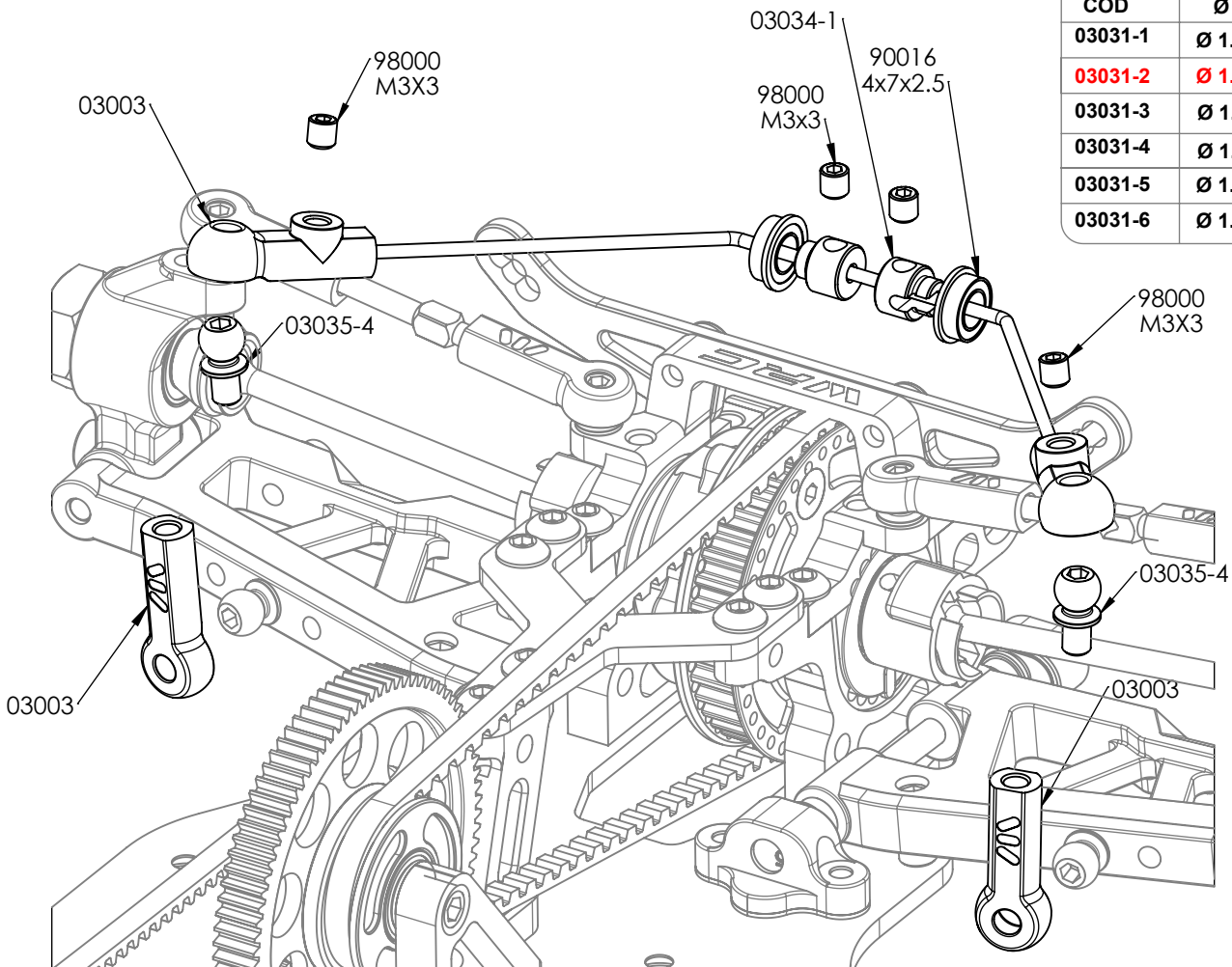

Rear Anti Roll Bar Options

COD	Ø	
03031-1	Ø 1.1	OPTIONAL
03031-2	Ø 1.2	STANDARD IN KIT
03031-3	Ø 1.3	OPTIONAL
03031-4	Ø 1.4	OPTIONAL
03031-5	Ø 1.5	OPTIONAL
03031-6	Ø 1.6	OPTIONAL

Shock Absorbers

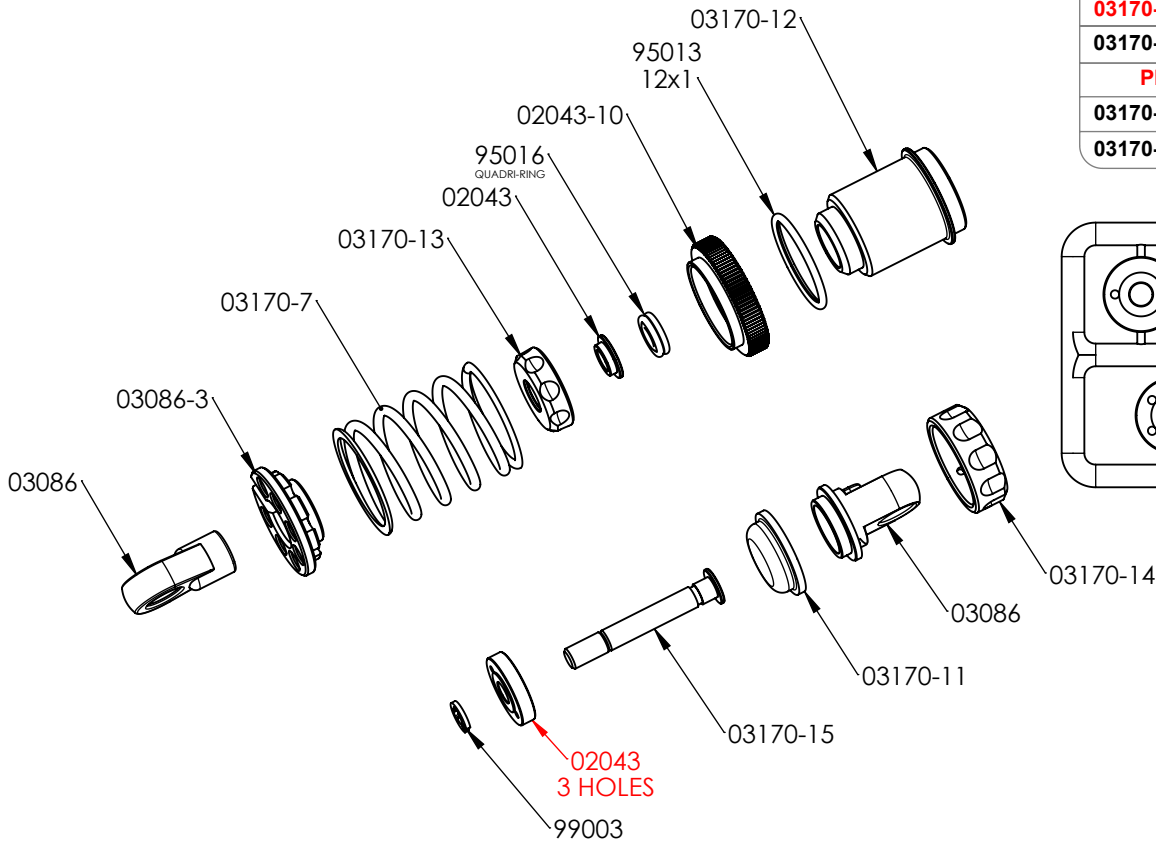

SPRINGS		
COD	Force (lb)	COLOUR
03170-5	2.1	BLACK
03170-6	2.2	YELLOW
03170-7	2.3	RED (IN KIT)
03170-8	2.6	BLUE
PROGRESSIVE SPRINGS		
03170-9	1.3-2.9	FUCHSIA
03170-10	1.4-3.5	GREEN

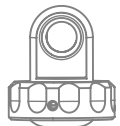
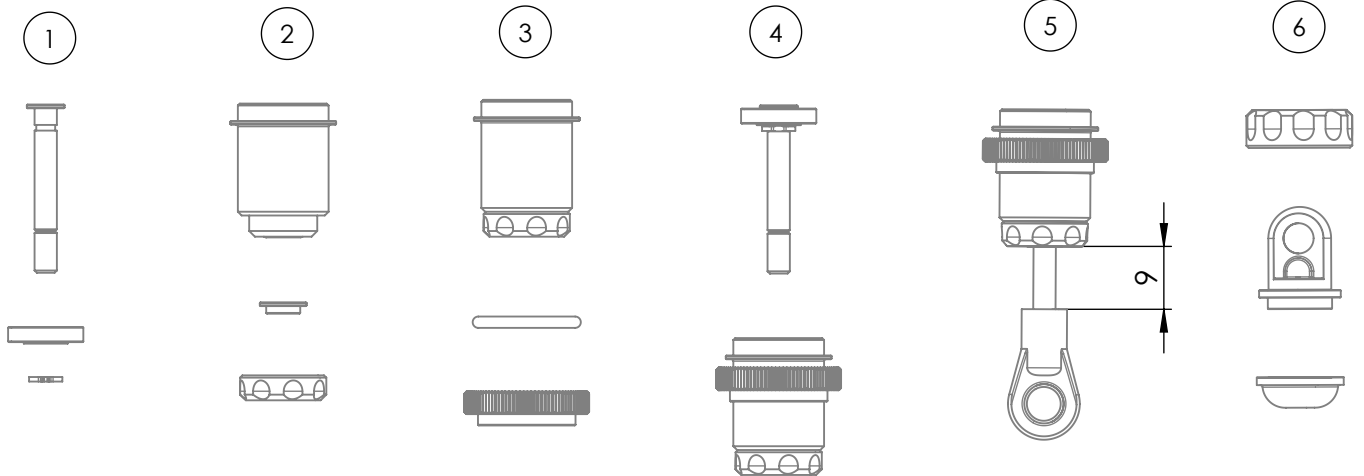
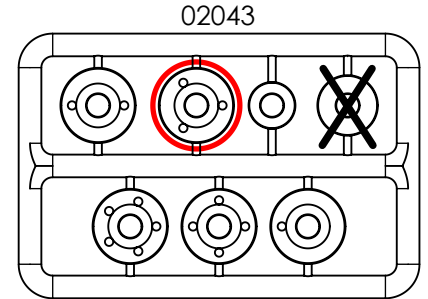

SHOCK FILLING

Fully extend the piston rod so the piston is at the bottom of the shock body.
 Hold the shock upright and fill the shock body with shock oil as in the picture.
 Let the oil settle and allow air bubbles to rise to the top.
 Slowly move the piston up and down until no more air bubbles appear.
 Add shock oil as necessary.
 Pull the piston rod most of the way out of the shock bod.
 Let the shock rest for 5 minutes to allow the air bubbles to scape.

FRONT **REAR**

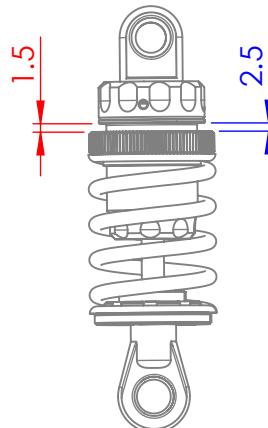

P-ONE SHOCKS OIL	
CODE	CST
SO-350	350
SO-400	400 (IN KIT)
SO-450	450
SO-500	500
SO-550	550
SO-600	600
SO-650	650
SO-700	700
SO-800	800

Rear Suspensions

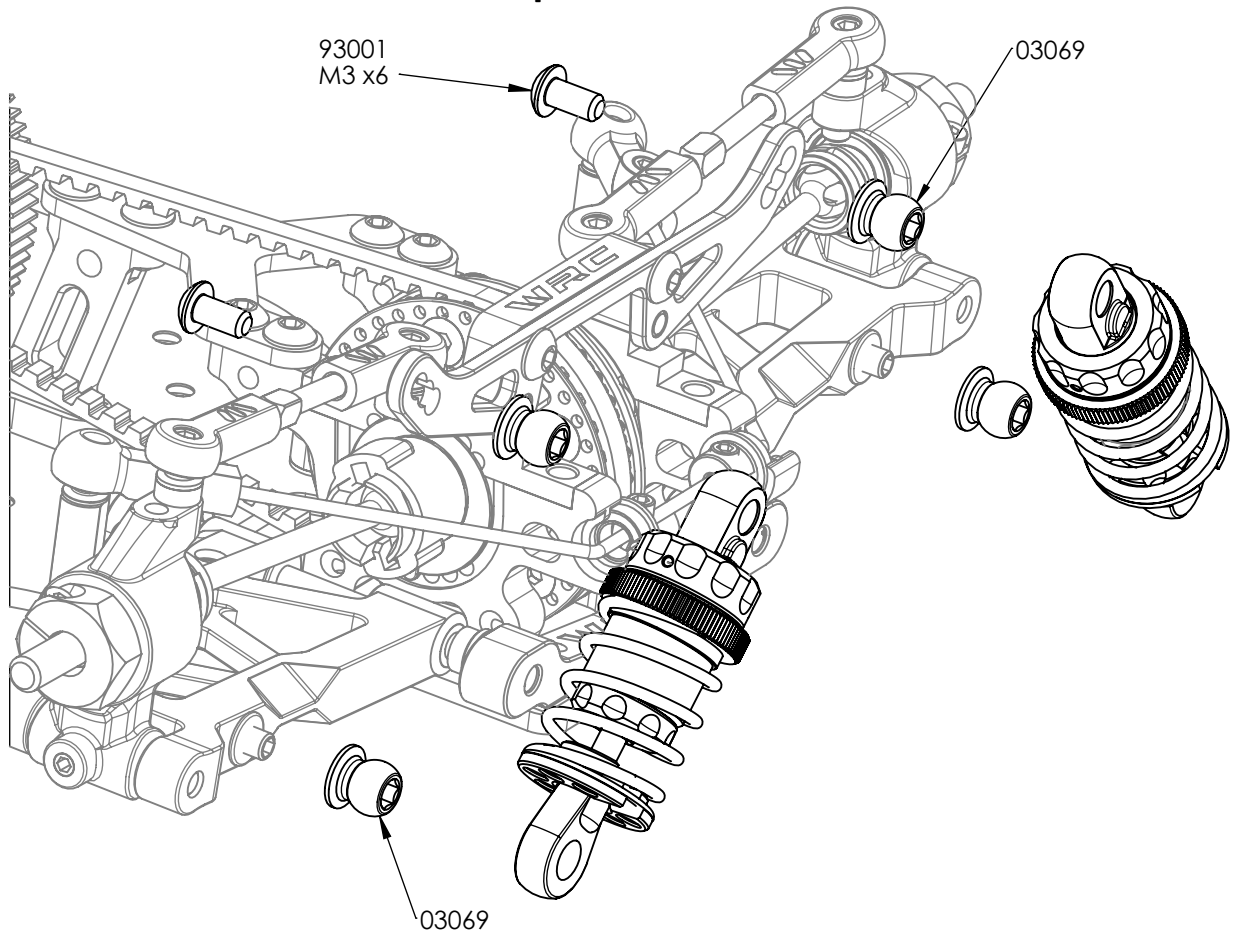

Front Suspensions

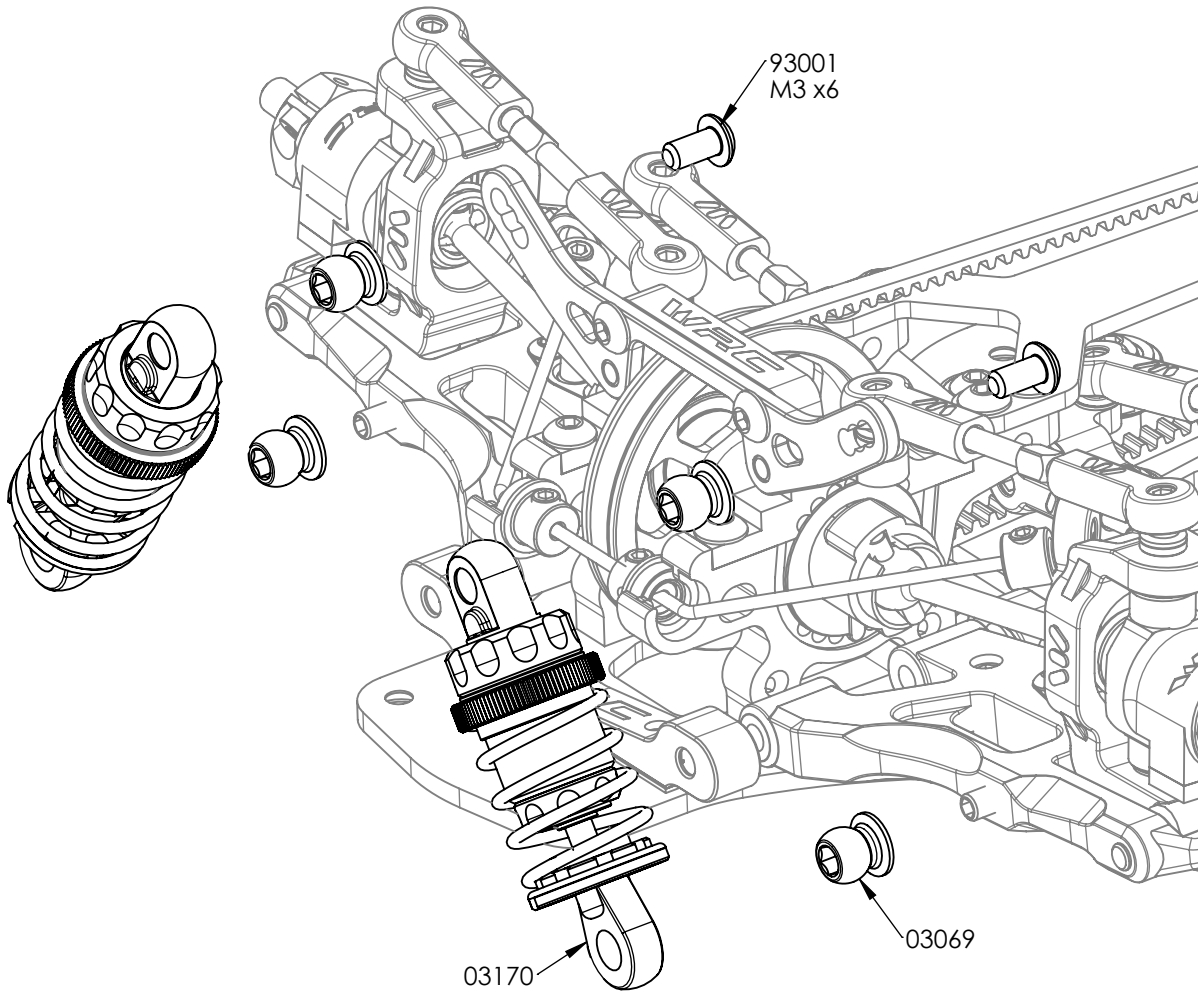

Battery Holder

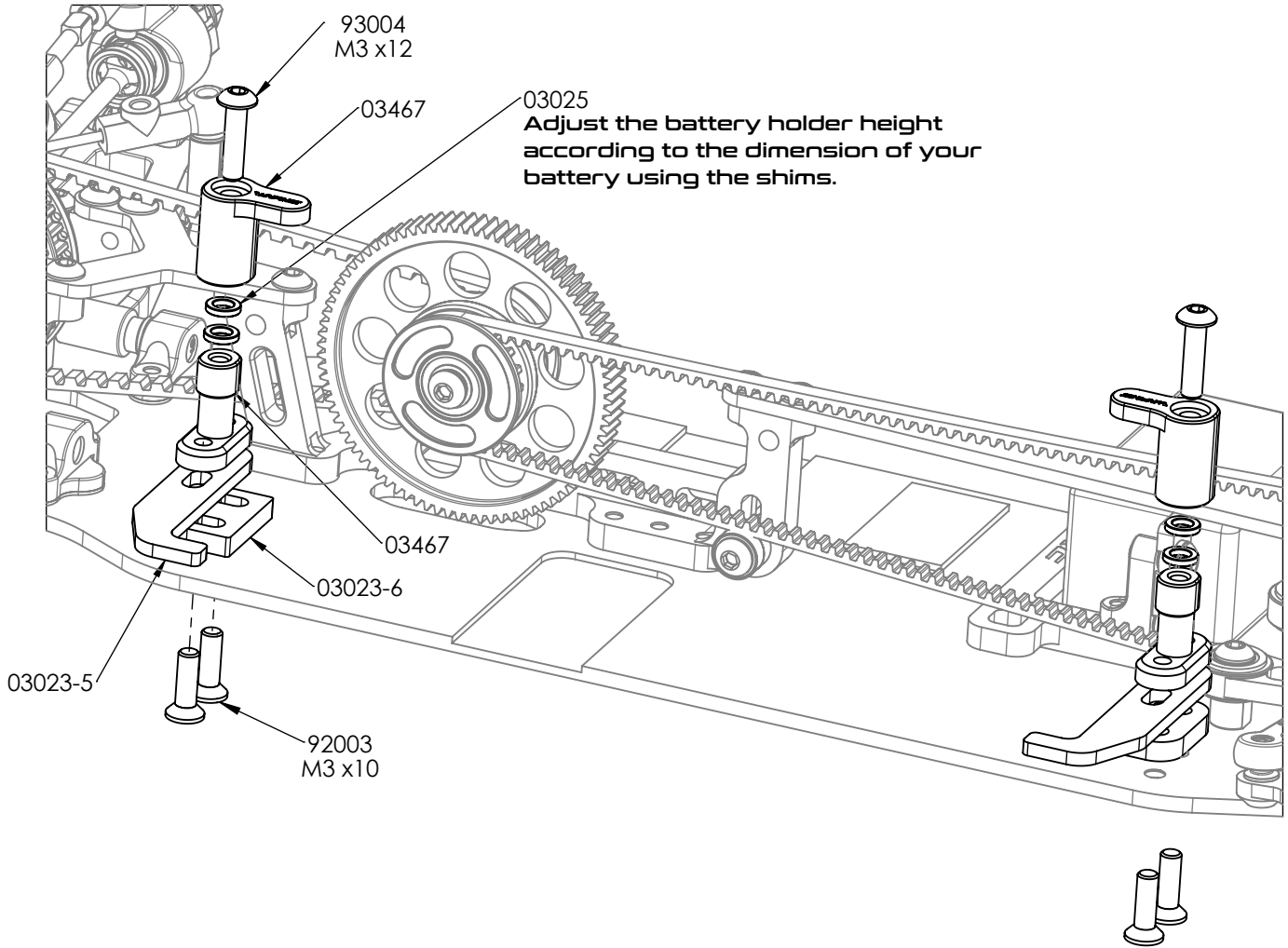

Battery Holder Adjustments

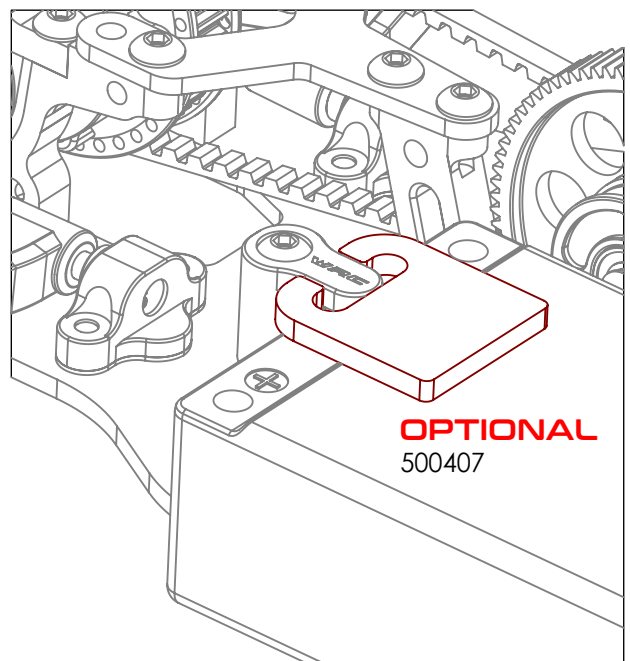
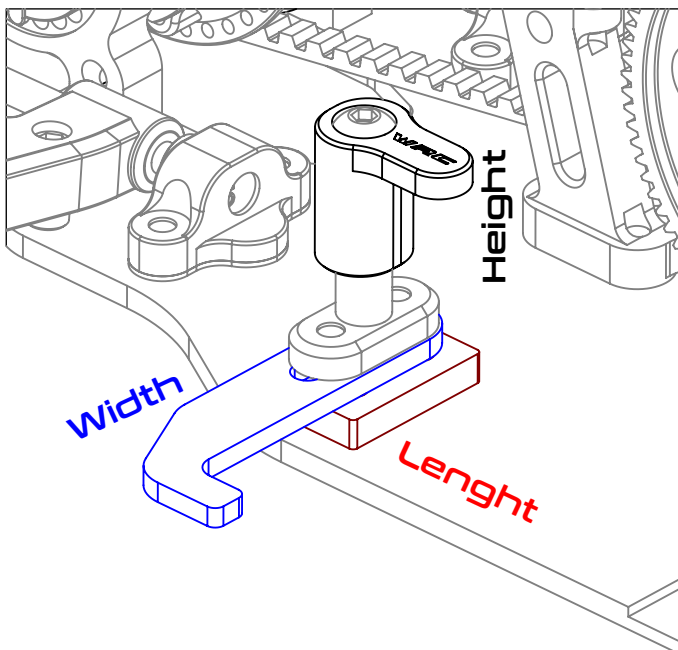

This optional battery holder is designed to hold the battery laterally, it's fixed to the battery using double side tape. By using this part you can delete the lateral battery holder.

Front Body Support and Bumper

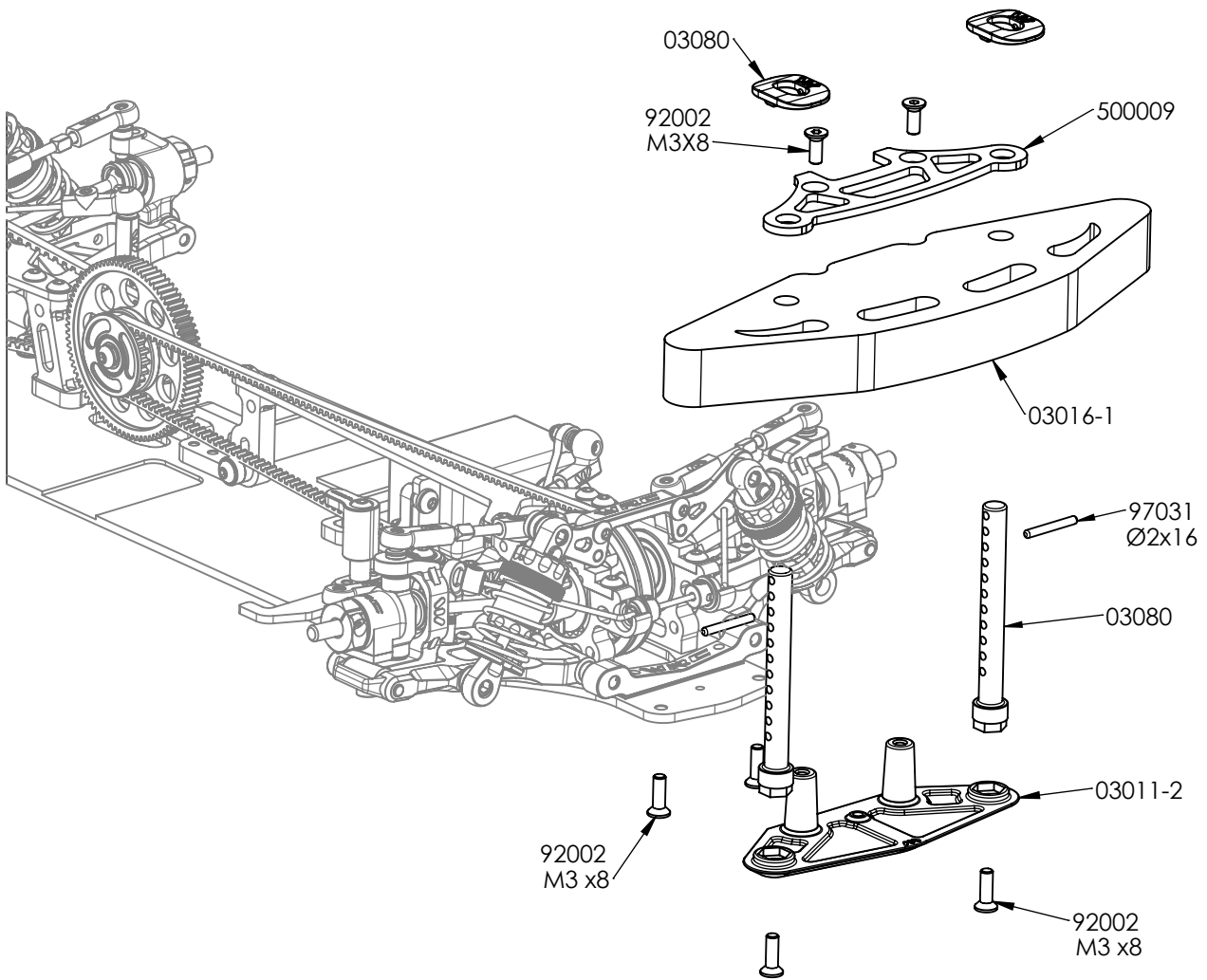

Rear Body Support

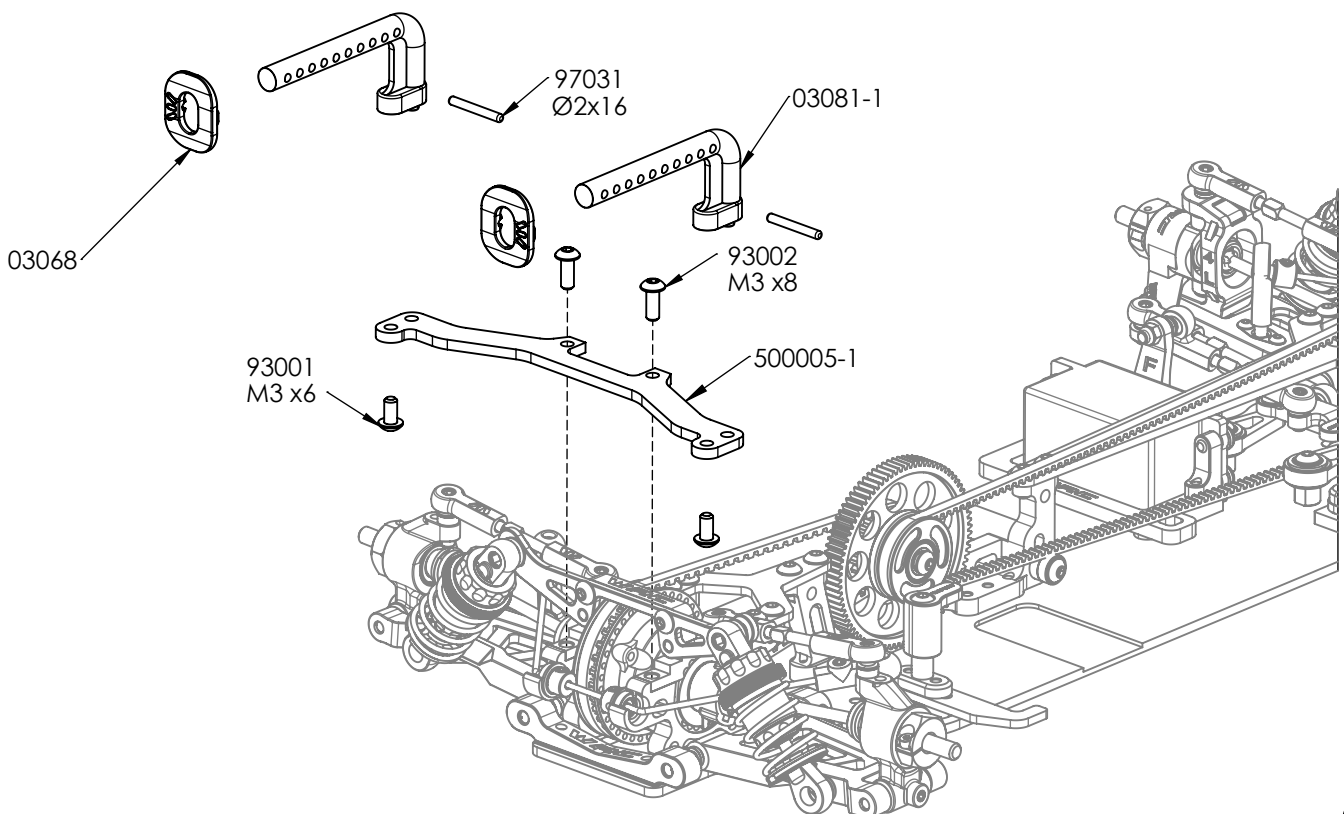

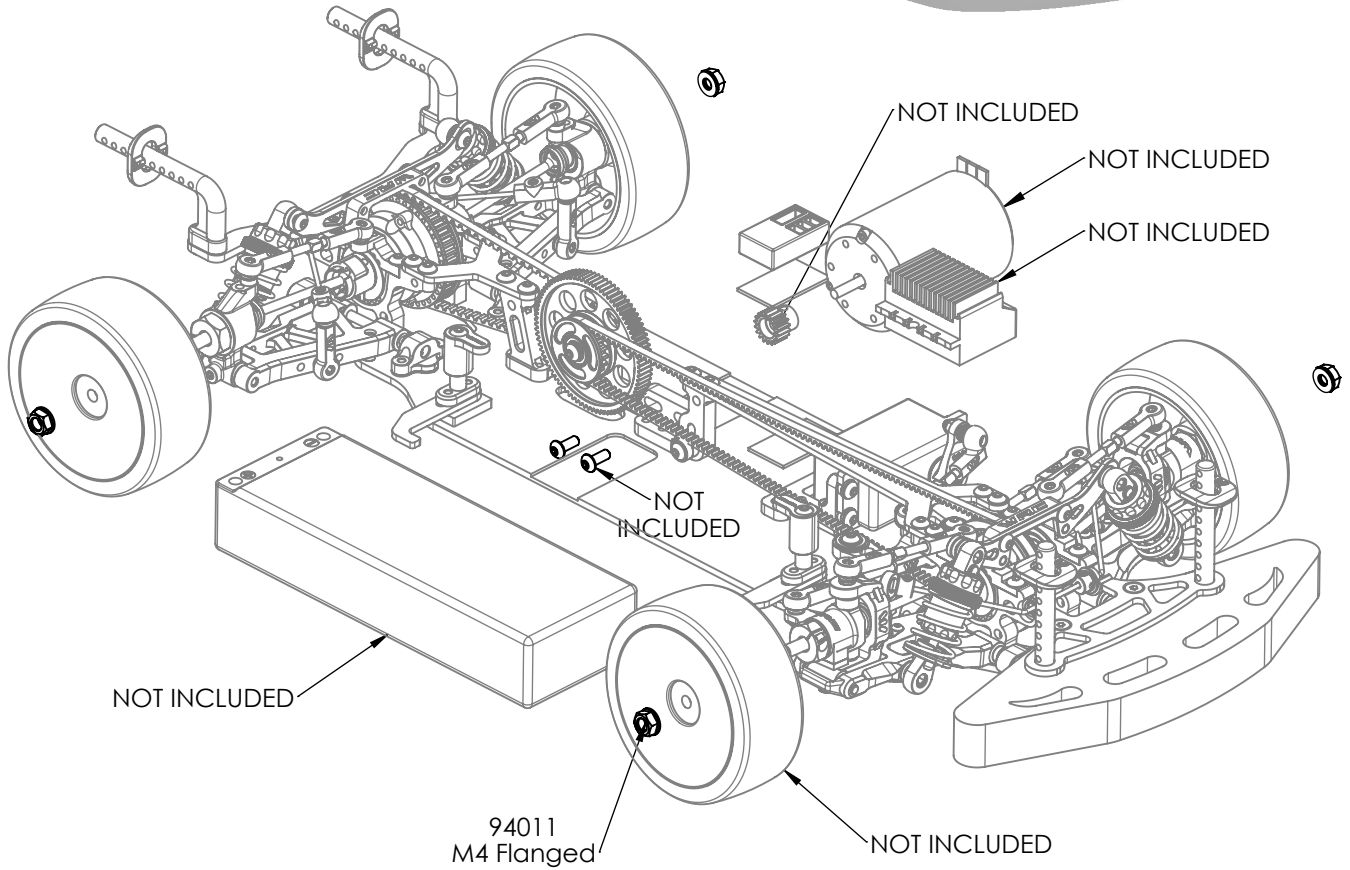
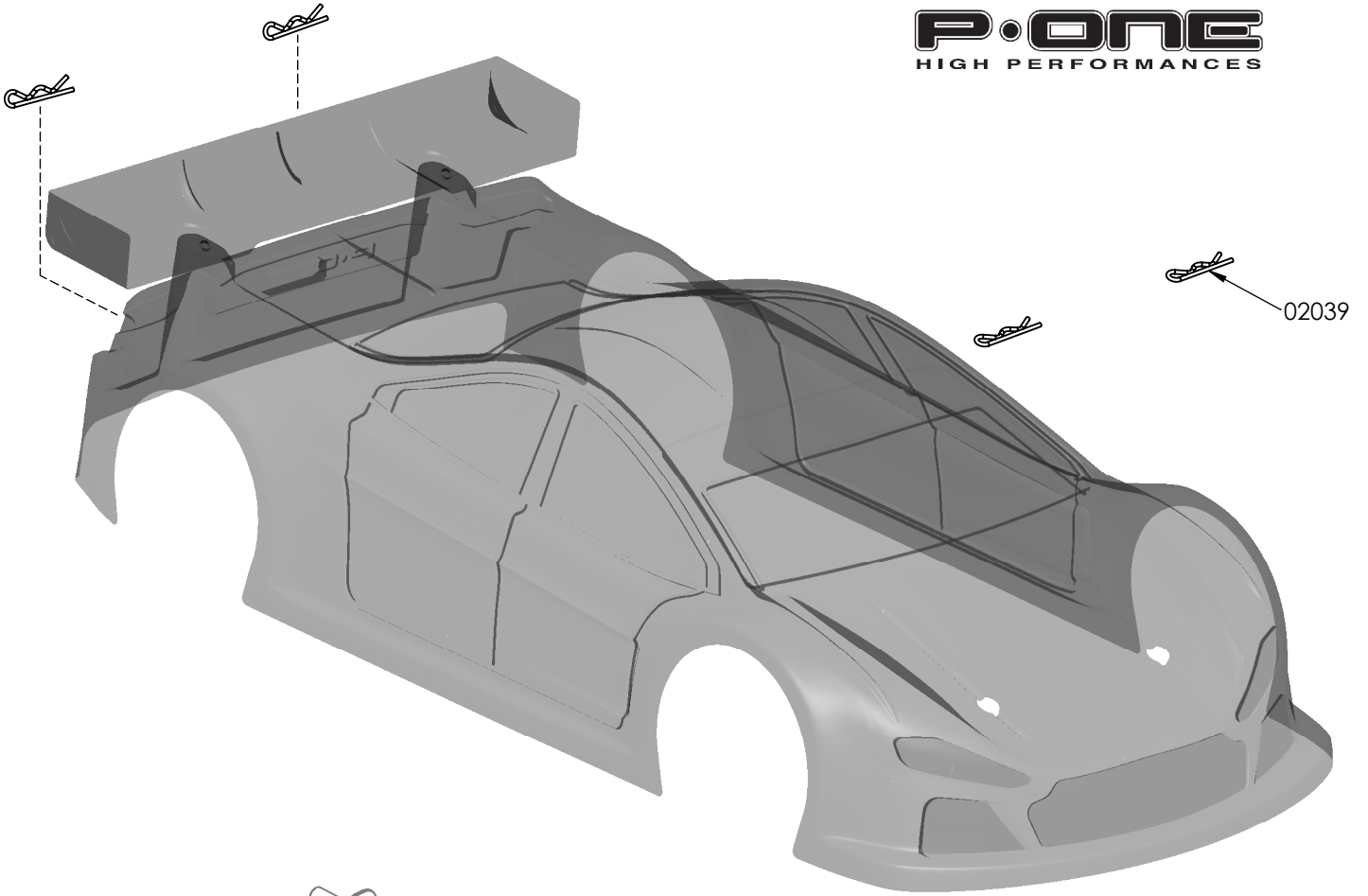

NAME _____
 DATE _____
 TRACK _____

TRACK CONDITION

SURFACE	<input type="checkbox"/> SMOOTH	<input type="checkbox"/> MEDIUM	<input type="checkbox"/> BUMPY
SIZE	<input type="checkbox"/> TIGHT	<input type="checkbox"/> MEDIUM	<input type="checkbox"/> FAST
TRACTION	<input type="checkbox"/> LOW	<input type="checkbox"/> MEDIUM	<input type="checkbox"/> HIGH

TRANSMISSION

FRONT	<input type="checkbox"/> SOLID AXLE	OIL
	<input type="checkbox"/> DIFFERENTIAL	
REAR	<input type="checkbox"/> DIFFERENTIAL	
PINION		SPUR GEAR
FINAL DRIVE RATIO		

SHOCKS

SPRINGS:	COLOUR
FRONT	
REAR	
OIL:	
PISTON:	
LENGHT /mm	

ANTI-ROLL BAR

FRONT	mm
REAR	mm
BODY	WING

ROLL CENTER

FRONT	mm
REAR	mm

ECCENTRIC BUSHINGS

FRONT - FRONT

2.5	2	<input type="checkbox"/>	0	<input type="checkbox"/>	2	2.5
3	1.5	<input type="checkbox"/>	0.5°	<input type="checkbox"/>	1.5	3

REAR - FRONT

2.5	2	<input type="checkbox"/>	STANDARD POSITION	<input type="checkbox"/>	2	2.5
-----	---	--------------------------	-------------------	--------------------------	---	-----

REAR - REAR

1	3.5	<input type="checkbox"/>	<input type="checkbox"/>	3.5	1
1.5	3	<input type="checkbox"/>	<input type="checkbox"/>	3	1.5
2	2.5	<input type="checkbox"/>	<input type="checkbox"/>	2.5	2
2.5	2	<input type="checkbox"/>	<input type="checkbox"/>	2	2.5
3	1.5	<input type="checkbox"/>	<input type="checkbox"/>	1.5	3
3.5	1	<input type="checkbox"/>	<input type="checkbox"/>	1	3.5

REAR - FRONT

2.5	2	<input type="checkbox"/>	STANDARD POSITION	<input type="checkbox"/>	2	2.5
-----	---	--------------------------	-------------------	--------------------------	---	-----

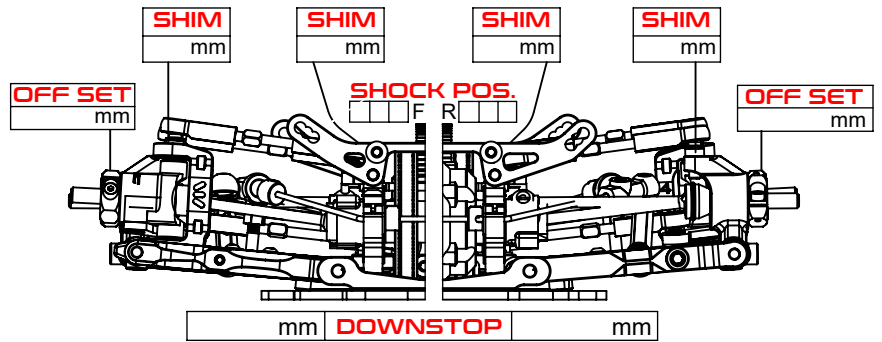

+ - FRONT CAMBER REAR - +

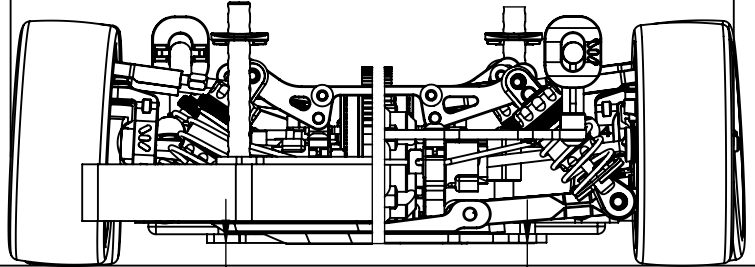

FRONT TOE

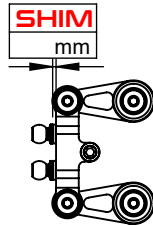
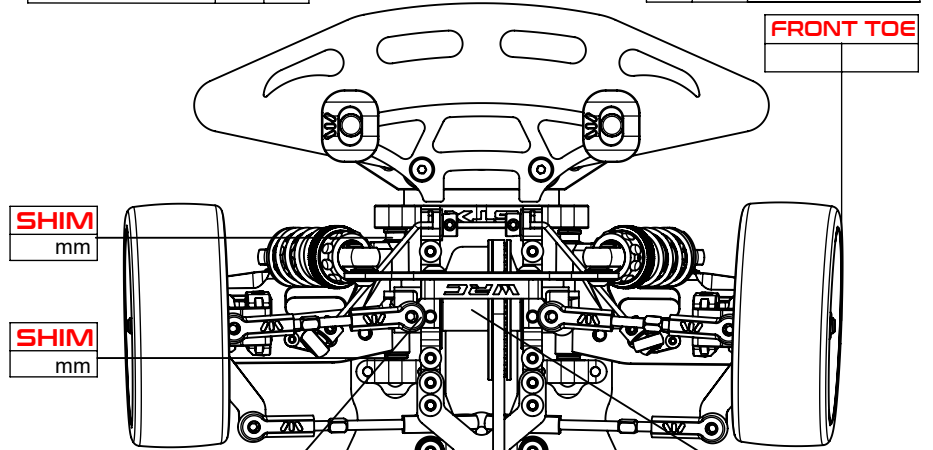

DIFF. POSITION
UP DOWN

REAR HUB
1 2

DIFF. POSITION
UP DOWN

REAR TOE
IN OUT

SHIM mm

SHIM mm

WIRC
PROFESSIONAL RC CAR

WWW.WIRCRACING.COM